

# electronic design

THE AUTHORITY ON  
EMERGING TECHNOLOGIES  
FOR DESIGN SOLUTIONS

March 2017 [electronicdesign.com](http://electronicdesign.com)

ONE  
**POWERFUL**  
ISSUE



**Digi-Key**  
ELECTRONICS

Access to  
**5 Million**  
Products Online

**DIGIKEY.COM**

\$10.00 Powered by Penton\*

# FUELING YOUR INNOVATION!

...the world's broadest selection  
of the newest electronic components  
in-stock for immediate shipment



1.800.344.4539  
**DIGIKEY.COM**



5 MILLION PARTS ONLINE | 650+ INDUSTRY-LEADING SUPPLIERS | 100% AUTHORIZED DISTRIBUTOR

Digi-Key is an authorized distributor for all supplier partners. New products added daily. Digi-Key and Digi-Key Electronics are registered trademarks of Digi-Key Electronics in the U.S. and other countries. © 2017 Digi-Key Electronics, 701 Brooks Ave. South, Thief River Falls, MN 56701, USA



## When it comes to power inductors, we're spreading things a little thin



(actual height)

In fact, with hundreds of options under 1.2 mm high,  
selecting the perfect low-profile power inductor is no tall order!

Let's face it, thin is in. From smart phones and wearables to all types of portable devices, there is constant pressure to pack more performance into the thinnest package possible.

To help, we continue to expand our line of mini, low-profile power inductors with footprints as small as 1.14 x 0.635 mm and maximum heights as low as 0.50 mm!

Select inductance values from 0.018 to

3300  $\mu$ H and current ratings up to 20 Amps.

Get the skinny on all our low-profile power inductors, including the new ultra-low loss XEL4012 Series with low inductance values that have been fully optimized for high frequency applications over 5 MHz.

Visit [coilcraft.com/lowprofile](http://coilcraft.com/lowprofile) today!



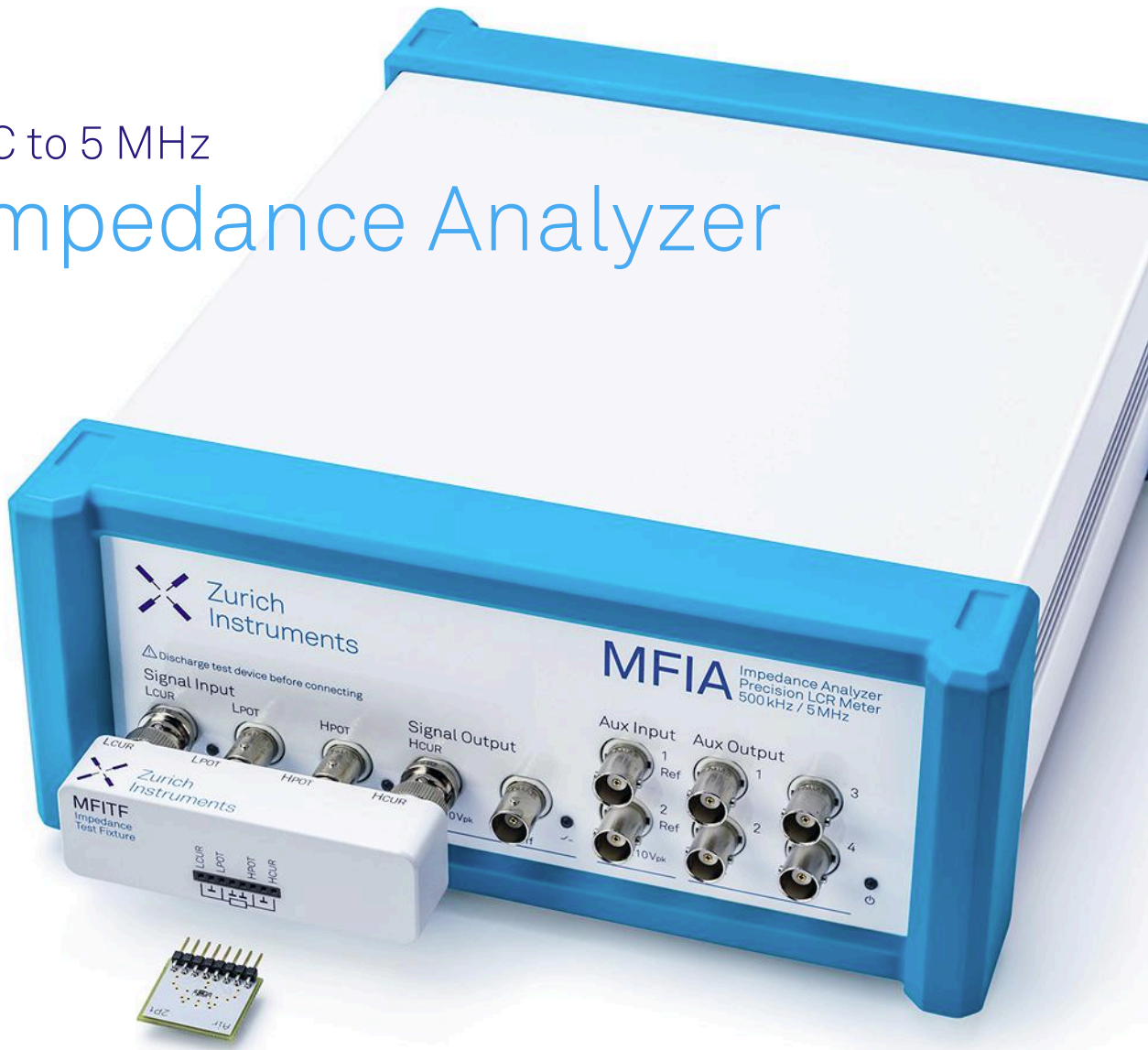
**APEC**  
Booth #1211

**Coilcraft**<sup>®</sup>

[WWW.COILCRAFT.COM](http://WWW.COILCRAFT.COM)

 [coilcraftdirect.com](http://coilcraftdirect.com)  
No min order. Next day delivery.

# DC to 5 MHz Impedance Analyzer



starting at  
**\$13,530**

## Applications

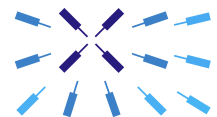
- Semiconductor wafer structures, Solar Cells, LED and LCD testing
- Tissue impedance analysis, Single cell impedance spectroscopy
- Quantum transport, Nanostructure characterization

## Key Features

- 0.05% basic accuracy
- 1 m $\Omega$  – 1 T $\Omega$
- 20 ms / data point
- Compensation Advisor
- Confidence Indicator

High accuracy, excellent measurement repeatability and a low temperature drift ensures fast and reliable results. In addition, the LabOne® software package includes a complete signal analysis toolset with an oscilloscope, parametric sweeper, FFT spectrum analyzer plus straightforward software interfaces to MatLab, Python, C, LabView and .NET.

Get in touch  
[www.zhinst.com](http://www.zhinst.com)  
[info@zhinst.com](mailto:info@zhinst.com)  
Intl. + 41 44 515 0410  
USA 617 765 7263



Zurich  
Instruments

# In This Issue

## FEATURES

- 14** **THERE'S MORE THAN ONE WAY TO SKIN AN OSCILLOSCOPE**  
Oscilloscopes started out as CRTs, but have morphed into a range of solutions—many of which look nothing like the original.
- 19** **TAKE THE EASY TEST ROAD (SOMETIMES)**  
Getting the job done right means making design tradeoffs and spending your time wisely—sometimes you can save time taking the easy road, sometimes not.
- 22** **EVERYTHING YOU NEED TO KNOW ABOUT THE NEW PoE STANDARD**  
Due to the increased number of Ethernet-connected devices demanding more power, a new IEEE 802.3bt standard is on the way.
- 26** **WILL PMIC ON-DEMAND REPLACE CATALOG DEVICES?**  
A new trend to customize power-management ICs on-demand uses interconnected power blocks, adds flexibility, and potentially disrupts the power device business.
- 29** **COM EXPRESS MODULES HANDLE 10 G ETHERNET**  
The latest computer-on-module technology includes platforms pushing 10 GbE.
- 31** **WIRELESS POWER PREPARES TO HIT THE MAINSTREAM**  
Fueled by consumer opinions about how devices should charge, companies look to make wireless charging more accessible while integrating “must-haves.”
- 35** **TAKE A PRACTICAL PATH TOWARD HIGH-PERFORMANCE POWER CONVERSION**  
Integrated GaN Power IC building blocks enable fast-switching topologies with simple “digital-in, power-out” capability.
- 42** **LEAD-ACID BATTERY APPLICATIONS DRIVE LI-ION MARKET**  
Neither consumer electronics nor electric vehicles are the main forces behind the growth in new battery technologies—instead it's coming from “everything else.”



14



19



31

## IDEAS FOR DESIGN

- 45** **ADDED ADC IMPROVES ANALOG SQUARE-ROOT EXTRACTION ACCURACY**
- 46** **SET DC-MOTOR SPEED WITH LIGHT-CONTROLLED MICROCONTROLLER CIRCUIT**
- 48** **LED-STRING DRIVER OPERATES FROM SINGLE CELL**

## COLUMNS & DEPARTMENTS

- 9** **EDITORIAL**  
NXP Spinout Nexperia Signals Changes in Market
- 10** **NEWS & ANALYSIS**
- 50** **NEW PRODUCTS**
- 56** **LAB BENCH**  
Do Circuit Boards Need More Wires?

42



### EDITORIAL MISSION:

To provide the most current, accurate, and in-depth technical coverage of the key emerging technologies that engineers need to design tomorrow's products today.

**ELECTRONIC DESIGN** (ISSN 0013-4872) is published monthly by Penton Media Inc., 9800 Metcalf Ave., Overland Park, KS 66212-2216. Paid rates for a one-year subscription are as follows: \$120 U.S., \$180 Canada, \$240 International. Periodicals postage paid at Kansas City, MO, and additional mailing offices. Editorial and advertising addresses: ELECTRONIC DESIGN, 1166 Avenue of the Americas, New York, NY 10036. Telephone (212) 204-4200. Printed in U.S.A. Title registered in U.S. Patent Office. Copyright ©2016 by Penton Media Inc. All rights reserved. The contents of this publication may not be reproduced in whole or in part without the consent of the copyright owner. For subscriber services or to order single copies, write to Electronic Design, PO Box 2100, Skokie, IL 60076. POSTMASTER: Send change of address to Electronic Design, PO Box 2100, Skokie, IL 60076. Canadian Post Publications Mail Agreement No. 40612608. Canada return address: IMEX Global Solutions, P.O. Box 25542, London, ON N6C 6B2.

Permission is granted to users registered with the Copyright Clearance Center Inc. (CCC) to photocopy any article, with the exception of those for which separate copyright ownership is indicated on the first page of the article, provided that a base fee of \$2 per copy of the article plus \$1.00 per page is paid directly to the CCC, 222 Rosewood Drive, Danvers, MA 01923 (Code No. 0013-4872/94 \$2.00 + \$1.00). Copying done for other than personal or internal reference use without the express permission of Penton Media, Inc. is prohibited. Requests for special permission or bulk orders should be addressed to the editor. To purchase copies on microfilm, please contact National Archive Publishing Company (NAPC) at 732-302-6500 or 800-420-NAPC (6272) x6578 for further information.



## THE FUTURE OF DIGITAL HEALTH

<http://electronicdesign.com/iot/future-digital-health>

Over the next 15 years, global healthcare will transform due to a perfect storm of clinical imperative, financial burden, and increasingly informed and empowered patients. A growing population, steadily decreasing healthcare budgets, and the rise of chronic diseases are putting pressure on doctors, healthcare providers, and governments to look to technology to provide the solution to these challenges.



## MITIGATING RISK OF LIABILITY FOR INDUCED INFRINGEMENT IN A GLOBAL ECONOMY

<http://electronicdesign.com/embedded/mitigating-risk-liability-induced-infringement-global-economy>

In the semiconductor and integrated-circuits arena, companies frequently design chips and components in technology hubs like Silicon Valley, then manufacture and sell them overseas to end-product manufacturers. One area in which this business model can clash with U.S. law is in the field of patents. Here's how CTOs and others can mitigate their risk.



## EMBEDDED FLASH STORAGE GETS SMALLER AND FASTER

<http://electronicdesign.com/blog/embedded-flash-storage-gets-smaller-and-faster>

Embedded developers have never had so many options when it comes to non-volatile, industrial-grade storage. Even the number of form factors is mind-boggling, ranging from conventional disk-drive formats—e.g., the now-ubiquitous 2.5-in. drives—to chips as well as modules like M.2.



## WHAT'S THE DIFFERENCE BETWEEN WINDOWS 10 IOT VERSIONS?

<http://electronicdesign.com/windows/what-s-difference-between-windows-10-iot-versions>

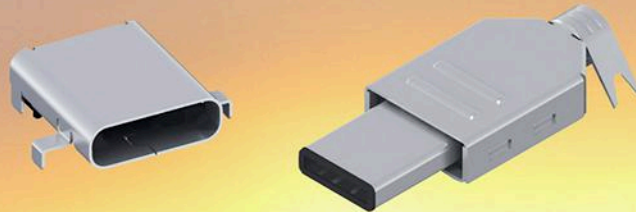
You may have seen more of Microsoft's Windows 10 IoT lately. It started with Windows 10 IoT Core, but has since progressed to include Windows 10 IoT Mobile Enterprise and Windows 10 IoT Enterprise. So how do you know which version fits where?

join us online  

Follow us on Facebook: <http://tinyurl.com/odz06hc> and Twitter: <http://tinyurl.com/k5pum39>

# THINK™

USB 3.1, TYPE C PLUGS & SOCKETS



- USB 3.1 - Type C
- Plugs are ideal for custom cable creation
- Sockets are available with Hybrid Mounting for Thru Hole Mount strength with a Surface Mount (SMT) configuration
- Smallest footprints of all high speed USBs
- 10Gbps top data transfer speed
- 20V (100W), 3Amp Thru-put
- Bi-Directional - data and charging port without separate power adapters needed
- No orientation, can be plugged in backwards and upside down
- Simplified connection to external devices
- Ideal for the latest electronic devices
- Request Catalog M65

IT'S WHAT'S ON THE INSIDE THAT COUNTS

**KEYSTONE**  
ELECTRONICS CORP.

[www.keyelco.com](http://www.keyelco.com) • (718) 956-8900 • (800) 221-5510



# 1.8nV Low Noise Dual P-Channel JFET Complement to N-Channel LSK489



- A Low-Noise Alternative to IC-Only Solutions
- Lower Noise and Lower Bias Current than IC-Only Solutions
- Low Noise < 1.8nV
- Low Capacitance: 4pf max
- Low Offset: 20mV max
- Complement to Dual N-Channel JFET - LSK489
- Ideal for Differential Amplifier Applications when used with the LSK489
- Ideal for Voltage Controlled Resistor Applications
- TO71, SOIC-8, SOT23-6, ROHS Packages



## EDITORIAL

CONTENT DIRECTOR: **NANCY K. FRIEDRICH** nancy.friedrich@penton.com  
 CONTENT PRODUCTION DIRECTOR: **MICHAEL BROWNE** michael.browne@penton.com  
 CONTENT PRODUCTION SPECIALIST: **ROGER ENGELKE** roger.engelke@penton.com  
 PRODUCTION EDITOR: **JEREMY COHEN** jeremy.cohen@penton.com  
 DISTRIBUTION: **VICTORIA FRAZA KICKHAM** SourceESBditor@penton.com  
 EMBEDDED/SYSTEMS/SOFTWARE: **WILLIAM WONG** bill.wong@penton.com  
 ANALOG/POWER: **MARIA GUERRA** maria.guerra@penton.com  
 CONTENT OPTIMIZATION SPECIALIST: **WES SHOCKLEY** wes.shockley@penton.com  
 ASSOCIATE CONTENT PRODUCER: **LEAH SCULLY** leah.scully@penton.com  
 ASSOCIATE CONTENT PRODUCER: **JAMES MORRA** james.morra@penton.com  
 CONTRIBUTING EDITOR: **LOUIS E. FRENZEL** lou.frenzel@penton.com

## ART DEPARTMENT

GROUP DESIGN DIRECTOR: **ANTHONY VITOLO** tony.vitolo@penton.com  
 SENIOR ARTIST: **JIM MILLER** jim.miller@penton.com  
 CONTENT DESIGN SPECIALIST: **JOCELYN HARTZOG** jocelyn.hartzog@penton.com  
 CONTENT & DESIGN PRODUCTION MANAGER: **JULIE JANTZER-WARD** julie.jantzer-ward@penton.com

## PRODUCTION

GROUP PRODUCTION MANAGER: **CAREY SWEETEN** carey.sweeten@penton.com  
 PRODUCTION MANAGER: **FRAN VAUGHN** fran.vaughn@penton.com

## AUDIENCE MARKETING

USER MARKETING DIRECTOR: **BRENDA ROODE** brenda.roode@penton.com  
 USER MARKETING MANAGER: **DEBBIE BRADY** debbie.brady@penton.com  
 FREE SUBSCRIPTION/STATUS OF SUBSCRIPTION/ADDRESS CHANGE/MISSING BACK ISSUES  
 OMEGA T | 847.513.6022 TOLL FREE | 866.505.7173

## SALES & MARKETING

MANAGING DIRECTOR: **TRACY SMITH** T | 913.967.1324 F | 913.514.6881 tracy.smith@penton.com

### REGIONAL SALES REPRESENTATIVES

AZ, NM, TX: **GREGORY MONTGOMERY** T | 480.254.5540 gregory.montgomery@penton.com  
 AK, CA, CO, ID, MT, ND, NV, OR, SD, UT, WA, WI, WY, W/CANADA: **JAMIE ALLEN** T | 415.608.1959 F | 913.514.3667  
 jamie.allen@penton.com

AL, AR, IA, IL, IN, KS, KY, LA, MI, MN, MO, MS, NE, OH, OK, TN: **PAUL MILNAMOW** T | 312.840.8462  
 paul.milnamow@penton.com

CT, DE, FL, GA, MA, MD, ME, NC, NH, NJ, NY, RI, PA, SC, VA, VT, WV, EASTERN CANADA:

**SHANNON ALO-MENDOSA** T | 978.501.7303 shannon.alo-mendoza@penton.com

### INTERNATIONAL SALES

GERMANY, AUSTRIA, SWITZERLAND: **CHRISTIAN HOELSCHER** T | 011.49.89.95002778

christian.hoelscher@hudsonmedia.com

BELGIUM, NETHERLANDS, LUXEMBURG UNITED KINGDOM, SCANDINAVIA, FRANCE, SPAIN, PORTUGAL:

**JAMES RHODES-BROWN** T | +011 44 1932 564999 M | +011 44 1932 564998 james.rhodesbrown@hudsonmedia.com

PAN-ASIA: **HELEN LAI** T | 886 2-2727 7799 helen@twoway.com.com

PLEASE SEND INSERTION ORDERS TO: orders@penton.com

PENTON REPRINTS: **WRIGHT'S MEDIA** T | 877.652.5295 penton@wrightsmedia.com

### LIST RENTALS:

SMARTREACH CLIENT SERVICES MANAGER: **JAMES ADDISON** T | 212.204.4318 james.addison@penton.com

### ONLINE

PRODUCT DEVELOPMENT DIRECTOR **RYAN MALEC** ryan.malec@penton.com

## DESIGN ENGINEERING & SOURCING GROUP

EXECUTIVE DIRECTOR OF CONTENT AND USER ENGAGEMENT: **NANCY K. FRIEDRICH**

GROUP DIRECTOR OF OPERATIONS: **CHRISTINA CAVANO**

GROUP DIRECTOR OF MARKETING: **JANE COOPER**

## PENTON

1166 AVENUE OF THE AMERICAS, 10TH FLOOR  
 NEW YORK, NY 10036 T | 212.204.4200



Electronic Design | Machine Design | Microwaves & RF | Source ESB | Hydraulics & Pneumatics |  
 Global Purchasing | Distribution Resource | Power Electronics | Defense Electronics

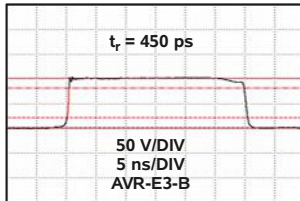
PENTON IS AN INFORMA BUSINESS



## Fast Pulse Test Systems from Avtech

Avtech offers over 500 standard models of high-speed pulse generators, drivers, and amplifiers ideal for both R&D and automated factory-floor testing. Some of our standard models include:

- AVR-E3-B:** 500 ps rise time, 100 Volt pulser
- AVRQ-5-B:** Optocoupler CMTI tests, >120 kV/us
- AVO-8D3-B:** 500 Amp, 50 Volt pulser
- AV-1010-B:** General purpose 100V, 1 MHz pulser
- AVO-9A-B:** 200 ps  $t_r$ , 200 mA laser diode driver
- AV-156F-B:** 10 Amp current pulser for airbag initiator tests



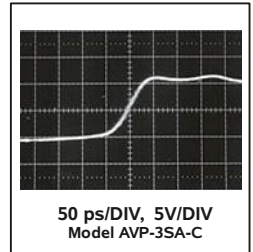
Pricing, manuals, datasheets and test results at:  
[www.avtechpulse.com](http://www.avtechpulse.com)

**AVTECH ELECTROSYSTEMS LTD.**  
Tel: +1-613-686-6675 Fax: +1-613-686-6679  
[info@avtechpulse.com](mailto:info@avtechpulse.com)

## 40 – 500 ps Rise Time Pulse Generators and Laser Diode Drivers



Avtech has pioneered the design of subnanosecond rise time pulse generators and drivers and now offers over 60 models which provide 40-500 ps rise times with 5 to 100 Volt output amplitude and PRF to 200 MHz. These models are ideal for testing high speed semiconductors and optoelectronics in both laboratory and factory floor applications. Customized models are also available.



And Model AVI-V-HV2A-B provides a 100 Volt, 300 ps rise time output!



Pricing, manuals, datasheets and test results at:  
[www.avtechpulse.com](http://www.avtechpulse.com)

**AVTECH ELECTROSYSTEMS LTD.**  
Tel: +1-613-686-6675 Fax: +1-613-686-6679  
[info@avtechpulse.com](mailto:info@avtechpulse.com)

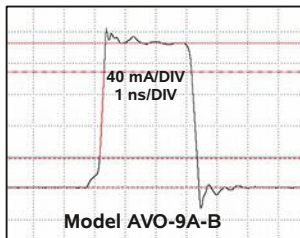
## Pulsed Laser Diode Drivers from Avtech



Each of the 19 models in the Avtech **AVO-9 Series** of pulsed laser diode drivers includes a replaceable output module with an ultra-high-speed socket, suitable for use with sub-nanosecond pulses.

Models with maximum pulse currents of 0.1A to 10A are available, with pulse widths from 400 ps to 1 us.

GPIO, RS-232, and Ethernet control available.



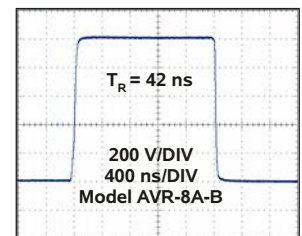
Pricing, manuals, datasheets and test results at:  
[www.avtechpulse.com/laser](http://www.avtechpulse.com/laser)

**AVTECH ELECTROSYSTEMS LTD.**  
Tel: +1-613-686-6675 Fax: +1-613-686-6679  
[info@avtechpulse.com](mailto:info@avtechpulse.com)

## 100 to 1000 Volt Lab Pulse Generators



Avtech offers a full line of 100, 200, 500, 700 and 1000 Volt user-friendly pulsers capable of driving impedances of 50  $\Omega$  and higher. The **AVR Series** is suitable for semiconductor and laser diode characterization, time-of-flight applications, attenuator testing, and other applications requiring 10, 20, or 50 ns rise times, pulse widths from 100 ns to 100 us, and PRFs up to 100 kHz. GPIO & RS-232 ports are standard, VXI Ethernet is optional.

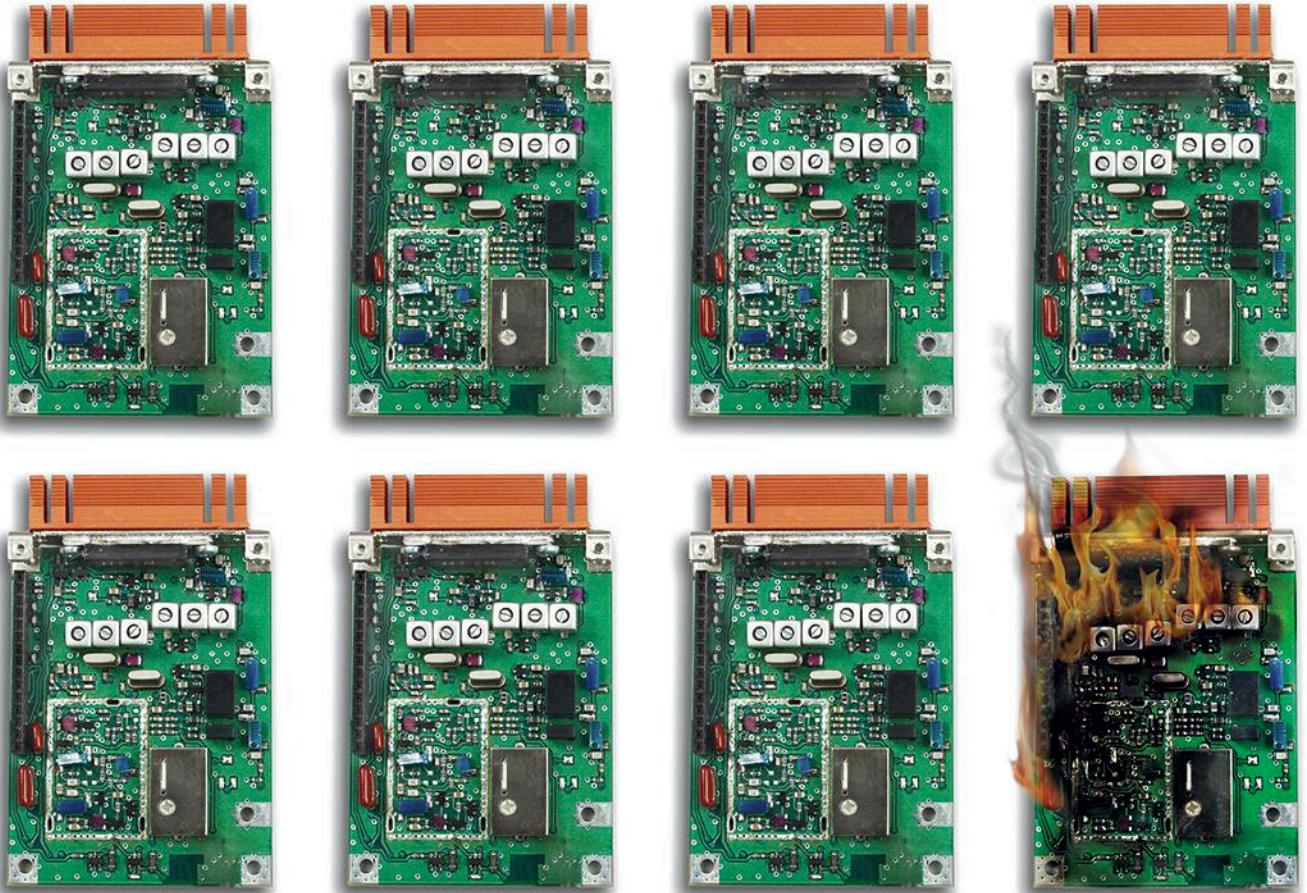


See additional test results at:  
<http://www.avtechpulse.com/medium>



Pricing, manuals, datasheets and test results at:  
[www.avtechpulse.com/medium](http://www.avtechpulse.com/medium)

**AVTECH ELECTROSYSTEMS LTD.**  
Tel: +1-613-686-6675 Fax: +1-613-686-6679  
[info@avtechpulse.com](mailto:info@avtechpulse.com)



# 7 out of 8 electronic devices recommend Bergquist Thermal Clad® Substrates

(The 8th device was unavailable for comment)

## World leading OEMs choose Bergquist.

For 25+ years Thermal Clad® has been effectively used in industries such as high-power LED lighting, automotive, power conversion, motor control, aerospace/military, computer, telecommunications and more.

## Don't get burned - Choose your insulated metal substrates carefully.

Bergquist supplies the world with some of the best solutions in the business:

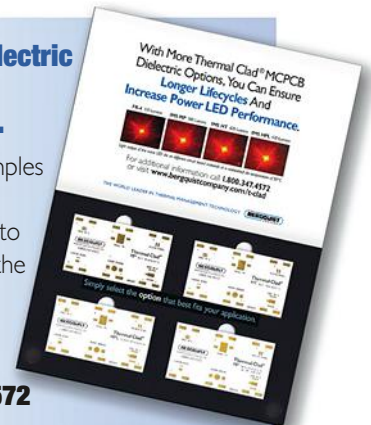
- Long-term dielectric strength
- Low thermal impedance
- U.L. Listed, high maximum operating temperature
- Long-term temperature testing

## Explore your dielectric options with a FREE Sample Kit.

This kit contains samples of select Bergquist Thermal Substrates to allow you to select the best option that fits your application.

To receive your kit, call **1-800-347-4572**

or qualify online at [www.bergquistcompany.com/coolkit](http://www.bergquistcompany.com/coolkit)



[www.bergquistcompany.com](http://www.bergquistcompany.com) 1.800.347.4572

9 5 2 . 8 3 5 . 2 3 2 2 f a x 9 5 2 . 8 3 5 . 0 4 3 0

18930 West 78th Street • Chanhassen, Minnesota 55317

**BERGQUIST**

Laminates Division



# NXP Spinout Nexperia Signals Changes in Market

**N**experia has been officially launched as an independent supplier of discrete, logic, and MOSFET devices. While NXP will focus on its high-performance mixed-signal business, Nexperia will focus on automotive applications accelerating the introduction of new products thanks to new investments in R&D and manufacturing.

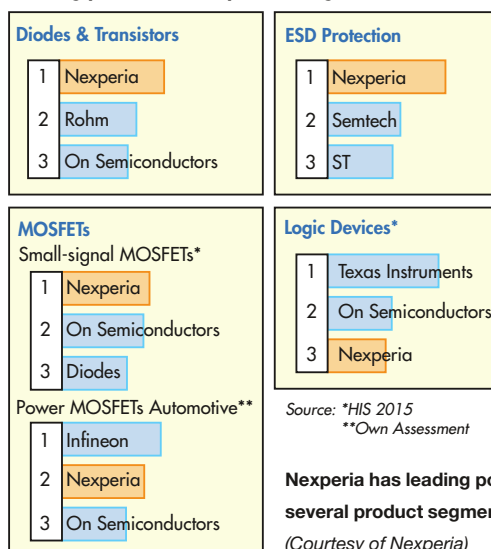
These actions by Nexperia will put pressure on automotive semiconductor competitors such as Infineon and Renesas in a market whose revenue will grow at annual rate of 7.5% from 2015 to 2022, according to a report from IHS Markit (Power Semiconductors in Automotive Report-2017). They may also shift the market in terms of international presence, as Nexperia is now owned by Beijing Jianguang Asset Management and private equity fund Wise Road Capital. They are just two of the many Chinese companies with new interest in the semiconductor industry. Those interests have increased since China's government started actively improving the domestic market with its "Made in China 2025" plan to reduce dependency on foreign technology and replace semiconductor imports.

In terms of the deal, the standard product division of NXP, with its approximately 11,000 employees, was sold to the new owners for \$2.75 billion. Nexperia will produce around 85 billion devices a year. In 2016, revenues exceeded \$1.1 billion, garnering a market share of 30% in Europe, 15% in Asia, and 10% in U.S. Nexperia plans to address three key trends: power efficiency; protection and filtering; and miniaturization through their active devices (diodes and transistors, ESD protection, MOSFETs, and logic devices).

The automotive sector is very strong for Nexperia; most of its products are AECQ101-qualified. According to IHS 2015 and Nexperia itself, the company is in leading positions for small-signal MOSFETs and Power MOSFET-Automotive (see figure).

I had a chance to speak with Frans Scheper, CEO of Nexperia, who says, "The automotive market is very important to Nexperia because there is a significant amount of power electronic components in electric vehicles and hybrid electric vehi-

## Leading positions in all product segments



cles." When questioned about potential uses of gallium-nitride technology, Scheper says, "In the upcoming months we will be launching new products based on gallium-nitride technology."

Nexperia has two front-end manufacturing facilities (Manchester, UK; Hamburg, Germany) and three back-end packaging plants (Guangdong, China; Seremban, Malaysia; Cabuyao, Philippines). Just recently, Nexperia upgraded its UK chip fab from 6- to 8-in. wafers. Scheper notes, "Because Nexperia will continue to source its front-and back-end production from its current manufacturing sites, there will be no disruption in our supply chain or other processes, so customers and partners can be fully assured that they will continue to receive excellent products and exceptional service."

In addition, Nexperia will continue to implement the same quality standards that it used when it was part of NXP. These include ISO9001, ISO/TS 16949 Automotive, ISO14001 Environmental, OHSAS18001 Health and Safety, etc.

# News

## DRAFT EXECUTIVE ORDER Pushes for Review of H-1B Visa Program

**T**he Trump administration is mulling over a broad review of the H-1B visa program that lets thousands of foreign engineers and computer scientists work in the United States, according to a draft of an executive order leaked to several news organizations.

This year, almost a quarter of a million foreign nationals applied for H-1B visas, which enable them to temporarily live and work in the United States at the company that applied for the visa. Though only 85,000 of those applications will be approved and around a quarter of the visas are for graduate students, technology companies and chipmakers use H-1B visas to fill entry-level jobs and hire international college graduates.

But critics, including some electrical engineers and small businesses, say the program has a dark underbelly. They say that aspects of the H-1B program choke off jobs for American engineers and that the visas allow large corporations to save money by outsourcing jobs to imported workers. The random lottery drawing for H-1B visas is also contentious.

If signed, the draft order would launch an investigation into “the extent of any injury to U.S. workers caused by the employment in the United States of foreign workers admitted under nonimmigrant visa programs,” which includes the H-1B and the L-1 visa for employees that have worked in a foreign branch of a company and request transfer to the U.S.

A final report would be due 18 months after the order is signed.

The draft lacks specific alterations to the H-1B program, but the Department of Labor review would seek ways to make the application process more efficient and benefit only “the best and brightest,” a phrase that H-1B critics have used for years to highlight the workers that the program is ignoring.

The status of the executive order is unclear. Written by Andrew Bremberg, the director of the Domestic Policy Council, the leaked document could be anything from a rough draft to the final version. A future version could be vastly different.

*(Image courtesy of Thinkstock)*



The draft was first published in late January by the news website Vox. Bloomberg and the Associated Press also obtained copies of the executive order, which *Electronic Design* could not independently verify.

President Donald J. Trump criticized the H-1B program during his presidential campaign and has folded opponents of the program into his cabinet. At one point that he invited former Disney workers who lost their jobs to H-1B replacements to speak at a Florida rally. New Attorney General Jeff Sessions has pushed to completely eliminate H-1B visas for years.

But the fact that the draft wants to start with a review of the visa program could mean that Trump intends to keep the program running. If signed, the executive order would follow Trump's immigration ban on countries including Iran and Syria. Google and Microsoft, which both hire H-1B workers from those countries, were two of the highest-profile companies to speak out against that ban.

In electrical engineering, the H-1B program has a spotted history. In a 2013 *Electronic Design* survey, 19% of respondents said their companies used the H-1B visa program, but many were concerned about the visa's negative impact. Though only 9% felt personally threatened by the program, over 40% said that it cut into American engineering jobs.

That has been the refrain among the program's critics.

Many proposed changes targets how outsourcing companies, which exploit H-1B visas to import workers for entry-level technology jobs, operate.

The IEEE-USA, a leading American trade group for electrical engineers, has urged giving priority to companies that pay higher wages and hire more experienced engineers. Zoe Lofgren, a California Democratic representative, proposed a bill last month that would favor visas for higher-paying jobs. Under her bill, a fifth of the H-1B slots would be reserved for small businesses.

"My legislation refocuses the H-1B program to its original intent—to seek out and find the best and brightest from around the world, and to supplement the U.S. workforce with talented, highly paid, and highly skilled workers who help create jobs here in America, not replace them," said Lofgren in a statement.

Lawmakers have also presented H-1B bills in Congress. Last month, Chuck Grassley, a Republican Senator from Iowa, and Dick Durbin, a Democratic Senator from Illinois, reintroduced a bill to prioritize H-1B applicants with advanced degrees and high-paying job offers. They first proposed the legislation in 2007.

"Congress created these programs to complement America's high-skilled workforce, not replace it," Grassley said in a statement. The law would also require companies to make a "good faith" effort to hire American workers first. ■

---

## CHINA'S TSINGHUA UNIGROUP Invests \$30 Billion in Memory Chip Fab

**AFTER FAILING TO** buy influence and insight from American memory chip makers, Tsinghua Unigroup, the national champion for China's aggressive push into semiconductors, said that it would build a manufacturing plant for its own technology.

The move is the latest and most expensive twist in a government-supported plan to replace over \$200 billion in semiconductor imports with Chinese-made chips. China is current limited in its ability to supply memory chips for its vast electronics industry, which is brimming with inexpensive smartphones and other low-end devices.

Tsinghua has announced plans to build a \$30 billion memory chip factory in Nanjing, China. To start, the company said that it would invest \$10 billion to construct the factory and produce its first 100,000 chips. The company didn't mention any production timeline for the plant.

A state-controlled firm, Tsinghua is viewed as the public face of China's strategy to become a semiconductor superpower. The company spun out of Tsinghua University, whose alumni include current President Xi Jinping and other top government leaders. It also once employed Hu Haifeng, the son of the former president Hu

Jintao, as its ambassador to the Chinese Communist Party.

Tsinghua became the country's largest chip maker after it bought Spreadtrum Communications and RDA Microelectronics, two of China's largest mobile chip firms, in 2013. Tsinghua's chairman Zhao Weiguang has pledged to invest \$47 billion to become the world's third largest chipmaker by 2020.

The new factory will dovetail with other memory chip projects connected to Tsinghua. The Chinese chip foundry XMC is using government funding to build a \$24 billion memory chip factory in Wuhan. XMC is owned by a holding company, Yangtze River Storage Technology, which itself is controlled by Tsinghua.

Headed by a former executive at Semiconductor Manufacturing International Corporation, XMC has previously worked with Spansion to produce several types of flash memory. Spansion merged with Cypress Semiconductor in 2015.

The Nanjing factory will produce NAND chips, which are vital for everything from storing photographs in smartphones to playing videos on laptops. It will also make 3D NAND chips with layers of memory stacked in three dimensions to improve storage capacity. ■

## TOSHIBA TO SPIN OFF Memory Chip Business

**TRYING TO CHOK** off billions of losses from its nuclear power plant projects, Toshiba says it will spin off its memory chip business and seek out a cash infusion from outside investors.

The move comes after Toshiba said in January that it was preparing to write down several billion dollars related to construction delays on four nuclear reactors and the 2015 acquisition of a nuclear power construction firm, CB&I Stone and Webster.

An independent chip company could ease some of its financial stress, while severing links that might complicate its plans to sell a fraction of the business. But the company has not said what form the spinoff would take or how much it would sell.

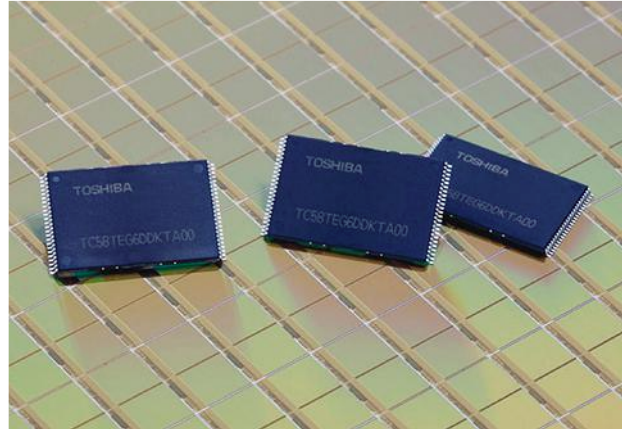
“Splitting off the memory business into a single business entity will afford it greater flexibility in rapid decision-making, and enhance financing options, which will lead to further growth of the business and maximize the corporate value of Toshiba,” the company said in a statement.

Toshiba, which is also facing \$60 million in fines over an accounting scandal, plans to spin off the business by March 31. Founded in 1901, the Japanese conglomerate sells everything from office phones and printers to nuclear power reactors and water treatment systems. It employs around 167,000 people.

Toshiba’s memory chip business is the second largest in the world after Samsung. It sells NAND flash memory based on its BiCS technology, an acronym for bits, cost, and scalable. In August 2016, it unveiled a new version of its memory with 64 layers of circuitry stacked in three dimensions for greater capacity, also known as 3D NAND.

Masashi Muromashi, Toshiba’s chief executive, has focused in recent years on further investing in its memory technology as well as factory production. The business, one of Toshiba’s most profitable, generated sales of around 845.6 billion yen or \$7.4 billion for the year ending last March.

In a statement, Toshiba said it would consider selling part of the



**Toshiba’s memory chip business is the second largest in the world after Samsung. It sells NAND flash memory based on its BiCS technology, an acronym for bits, cost, and scalable.** (Courtesy of Toshiba)

new company, which excludes its image sensor technologies. One potential investor could be Western Digital, the maker of hard disk drives and the owner of SanDisk, which for years has partnered with Toshiba on NAND manufacturing.

It is also possible that China’s Tsinghua Unigroup could make an offer. Over the last two years, the threat of regulatory action has forced it to abandon a \$23 billion deal for Micron Technology and a \$4.35 billion deal to acquire 15% of Western Digital. An investment would dovetail with its recently unsealed plans to build a \$30 billion memory chip fab in Nanjing, China.

Toshiba is not the only Japanese electronics maker to split its semiconductor unit in recent years. In the most recent example, Sony spun off its chip business with an eye toward moving its image sensors into new markets faster. The move came in 2015 as the company aimed for applications in drones and cars. ■

## A CIRCUIT FOR SENSORS That Never Stop Listening

**WITH THE ADDITION** of a tiny circuit that consumes little more than the power of a human cell, the batteries inside sensors could last for years sniffing out chemicals, listening for voice control keywords, or feeling for earthquakes.

The circuit, recently unveiled by researchers at the University of Bristol in England, is a new spin on the voltage detector, a device that monitors the health of power supplies inside things like cars and factory equipment. But while these devices normally chew through battery power to work, the new circuit can remain asleep until woken up by an electrical pinch from sensors.

The UB20M, as the new circuit is called, only wakes up an electronic device when something like an accelerometer feels movement or a microphone hears a sound, generating a volt-

age. That allows a sensor to keep watching its surroundings, consuming so little standby power it might as well be asleep, the researchers said.

“This is because it is able to respond to minute quantities of power from unpowered sensors,” said Bernard Stark, one of the researchers at the Bristol Electrical Energy Management Research Group, in a statement. “No battery or other power is needed for the device to stay alive and listening.”

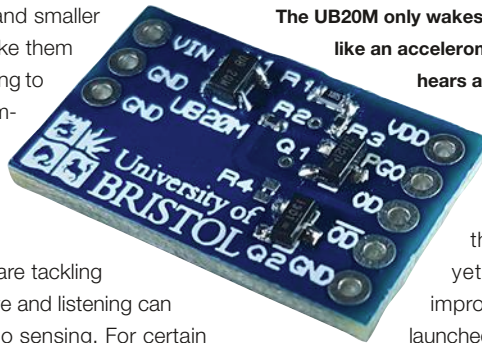
The invention of the circuit is one of the latest attempts to improve sensors, so that they operate for years without needing to be frequently recalibrated or recharged. That has become a major priority as companies deploy wireless sensors with an eye toward making everything from factories to farms more efficient.

Although sensors have grown cheaper and smaller over the years, it has proven difficult to make them more independent. Many companies are trying to make them more power efficient by using simplified wireless networks, energy harvesting chips that refuel batteries using light and vibrations, and new designs to make their readings less prone to drift over time.

But the University of Bristol researchers are tackling the fact that the energy to keep sensors alive and listening can far outweigh the energy used to actually do sensing. For certain types of wireless sensors, like security cameras or volcanic activity monitors, the battery expends lots of power listening for movements or short tremors.

The UB20M circuit only consumes a few trillionths of a watt and wakes up devices using a thousandth of the energy spent by existing detectors, providing what Stark described as “sensing that is continuous and free.” The result is battery life extended from months to years, the researchers said.

These benefits have not been lost on many other researchers and companies. A start-up called Vesper Technologies sells microphones that perform “quiescent sensing,” in which the device turns itself on when it hears a sound. Matt Crowley, Vesper’s chief executive, says that is indispensable for a new generation of devices, like the Amazon Echo and Google Home, which can be controlled with your voice.



**The UB20M only wakes up an electronic device when something like an accelerometer feels movement or a microphone hears a sound, generating a voltage.**

There are also potential military applications. For the Defense Advanced Research Projects Agency, that ability for sensors to be “asleep-yet-aware” could help soldiers identify improvised explosives. In 2015, the agency launched a program to design wireless sensors that could be sprinkled around a battlefield to listen for the particular radio signals that activate the explosives.

“It is the waiting for a specific event or activity that constrains mission life and drains the battery energy of these essential electronics,” said Troy Olsson, the N-Zero’s project manager, in a statement. “Our goal is to use the right signal itself to wake up the sensor, which would improve sensors’ effectiveness and warfighters’ situational awareness.”

The agency is aiming to complete the Near Zero Power Radio Frequency and Sensor Operations, or N-Zero, project by 2018.

The University of Bristol researchers are looking for commercial partners to use the circuit in connected door locks, forest fire sensors, and other applications. Another natural fit would be in fitness bands, as the circuit was developed as part of Sphere, a research program aiming to develop sensors for home health monitoring. ■

## GOOGLE OFFERS UP SOME DETAILS About Its Custom Security Chip for Servers

**SINCE GOOGLE SAID** last year that it had devised a custom chip for accelerating machine learning, there has been much chatter about the rise of specialized hardware for complex tasks like image recognition.

But the search engine company recently hinted that machine learning was not the only task that required custom silicon. In a recent overview of its data center security, Google said that it had devised “a hardware security chip” to verify the identity of devices inside its servers.

The chip is “currently being deployed on both servers and peripherals,” the company said. “These chips allow us to securely identify and authenticate legitimate Google devices at the hardware level.” It is unclear when the company first installed the chips, but they appear to be its latest strategy for storing security code.

Google added that with “each new generation of hardware, we strive to continually improve security: for example, depending on the generation of server design, we root the trust of the boot chain in either a lockable firmware chip, a microcontroller running Google-written security code, or the above mentioned Google-designed security chip.”

The security chip is another sign that internet companies are willing to invest in chips that fit the unique demands of their server workloads. Microsoft, for instance, using custom FPGAs in its cloud servers that can be programmed and optimized for an array of difficult chores. Facebook, too, has devised its own type of graphics processors.

Google said that its chip creates a hardware root of trust, which entails locking a cryptographic signature in a special part of the chip where it cannot be altered. Google said that its machines validate that code during each boot and update. The company did not immediately respond to a request for more information.

Google has been building custom servers for years, but until recently has been content to buy chips from companies like Intel. Google has quietly changed its tune, hiring chip designers and buying start-ups with tools for programming multicore processors. In 2010, it purchased a secretive company founded by former employees of P.A. Semi, which Apple bought in 2008 to design iPhone chips.

Google’s semiconductor plans became clearer last year. The first sign came in February, when it became known that the company had built a processor for network interface cards that connect servers to a larger network. Its first big chip announcement followed several months later in May at Google’s I/O developer conference.

Sundar Pichai, Google’s chief executive, revealed an accelerator chip for machine learning programs, which is said to be three processor generations ahead of other devices. The chip, he said, has been used to enhance Google’s search engine and an artificial intelligence program that has mastered one of the most devilishly complex board games in history, Go. ■

# There's More Than One Way to Skin an OSCILLOSCOPE

Oscilloscopes are one of the primary electronic diagnostic tools. They started out as CRTs, but have morphed into a range of solutions—many of which look nothing like the original.

Oscilloscopes are one of the primary electronic diagnostic tools, and there are a lot of vendors to choose from (see “Looking for an Oscilloscope? Check Out this List” on [electronicdesign.com](http://electronicdesign.com)). While all oscilloscopes generally looked similar when they first appeared, things have changed radically since then. For example, do you know the difference between a digital phosphor oscilloscope (DPO) and a digital storage oscilloscope (DSO) (see “What’s the Difference Between a DSO and DPO?”)?

With that in mind, here’s a little quiz: **Out of all the devices depicted in Fig. 1, can you select the oscilloscopes?**

- 1a. Tektronix model 531 was a successful, early oscilloscope.
- 1b. Keysight’s M9005A isn’t really an oscilloscope until adding one or more PXI Express cards. It does have a built-in system module.
- 1c. Rohde and Schwarz’s Scope Rider is a multifunction, handheld oscilloscope.
- 1d. BitScope’s USB-based oscilloscope even works with host platforms like the Raspberry Pi.
- 1e. National Instruments’ VB-8054 is designed to work with Virtual Bench software.
- 1f. Pico Technology’s PicoScopes are USB-based oscilloscopes that include additional features like a function generator.
- 1g. ADLINK’s PXIe3-9848 is an eight-channel PXI Express capture board designed for a PXIe chassis.
- 1h. Tektronix’s DPO70000SX has a 70-GHz bandwidth and 200-Gsample/s sample rate. Multiple units can be synchronized and managed together.

The Tektronix 531 (Fig. 1a) was not the first oscilloscope, but it was one of the most memorable. It was developed in the 1950s and sold for more than 20 years. It cost a little more than \$1,000 and had a 10-MHz bandwidth. At the other end of the spectrum is the stackable Tektronix DPO70000SX (Fig. 1h).

The DPO70000SX is a 70-GHz oscilloscope with a 200-Gsample/s sample rate. The Asynchronous Time Interleaving (ATI) architecture is designed to minimize noise while maintaining the highest fidelity for real-time signal acquisition. Multiple units can be synchronized and managed together, and it has a separate USB-based control panel with dials and buttons. The unit does have a small display screen, but it’s also designed to work with an external monitor.

Of course, not all oscilloscopes are as large or expensive, and many have features and probes designed for specific applications, such as power-integrity analyzers. Most still incorporate integrated displays, and some are even portable. Take Rohde & Schwarz’s Scope Rider (Fig. 1c), for instance, which has a four-hour runtime. It is first and foremost a lab oscilloscope with a 10-bit ADC, but also acts as a logic analyzer, protocol analyzer, data logger, digital multimeter, spectrum analyzer, harmonics analyzer, and frequency counter. It does have a 7-in., 800- by 480-pixel capacitive touch display, plus connectivity support that includes USB, Ethernet, and Wi-Fi.

## HEADLESS TEST EQUIPMENT

Embedded designers can pack a processor and oscilloscope support hardware into a compact package like the Scope Rider,





but sometimes an integrated solution is not a requirement. There are advantages to using a separate PC, including a wider selection of hosts.

BitScope's USB-based oscilloscope (Fig. 1d) is an example of a class of compact test-and-measurement devices that significantly reduces the cost and size of the acquisition system. Some of these systems target students and the maker space with low-cost alternatives. While these may be less expensive, they can still pack a punch.

For example, the dual-channel BitScope Micro has a 20-MHz bandwidth with a 12-bit ADC. It also features a pair of analog comparator channels and a six-port logic analyzer. In addition, there's a built-in analog waveform and digital clock generator. It can handle a range of protocols, including serial, SPI, I<sup>2</sup>C, and CAN.

Not bad for a 14 g package that's also water-resistant. The PC software provides the user interface, and there's an API, too. The BitScope hardware will also work with non-PC platforms like the Raspberry Pi—the latest version of which can handle four BitScopes thanks to four built-in USB ports. It is also a handy remote diagnostic platform that can be accessed via its network interface.

Moving to a bigger box allows additional features and more hardware to be included in a system. Pico Technology's PicoScopes are USB-based test-and-measurement systems. The low-end PicoScope 2000 series (Fig. 1f), which includes a large, 128-Msample memory and 100-MHz bandwidth, starts at just over \$100. The high-end PicoScope 9000 has a 20-GHz bandwidth and goes for more than \$10,000. Still, all things are relative, as fully integrated oscilloscopes with this functionality are also expensive.

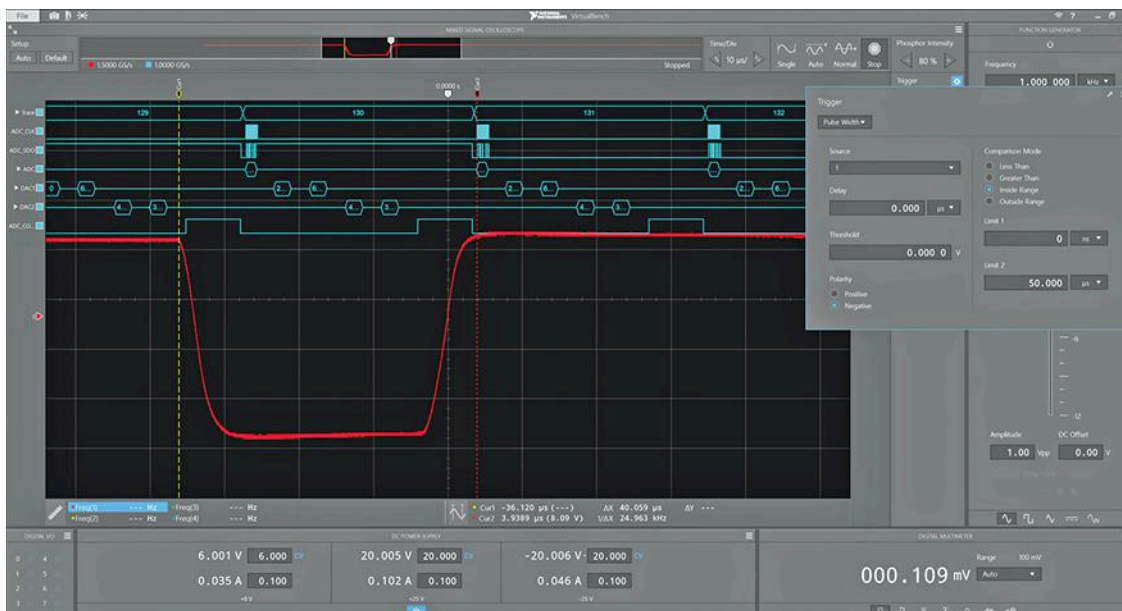
Another advantage of these smaller systems is that they can be placed closer to a device under test (DUT). Probes and cables help, but there are limits and tradeoffs. Having such flexibility helps in many instances. On the other hand, though, the extra cabling and PC could take up more room on a lab bench.

The modular approach allows designers to choose the features they need. Still, it's often more economical to deliver an all-in-one instrument like National Instruments' (NI) VB-8054 (Fig. 1e). The VB-8054 is a 350-MHz mixed-signal oscilloscope, protocol analyzer, arbitrary waveform generator, and digital multimeter, with a programmable dc power supply and its own digital I/O. It's designed to work with Virtual Bench software (Fig. 2), as well as NI's own LabVIEW programming environment. LabVIEW allows the VB-8054 to be incorporated into automated test and control systems.

**RACKING UP SCOPES**

Bus-based test-and-measurement systems have been used to provide modular solutions to test, measure, and control applications. These can be used as transient diagnostic tools like oscilloscopes through permanent installations such as production lines.

The two primary solutions in this space include PXI System Alliance's PCI eXtensions for Instrumentation (PXI) based on PICMG's CompactPCI and CompactPCI Express standards, and the VXIbus Consortium's VME eXtensions for Instrumentation (VXI) based on VITA's VME standards. These standards add timing support necessary for synchronization between boards.



2. National Instruments' Virtual Bench software works with platforms like VB-8054 to provide a flexible PC-based test-and-measurement environment.



# SMALL SIZE BIG PERFORMANCE

## NEW MICROSIZE HIGH VOLTAGE POWER SUPPLIES

The new PMT Series of high voltage, microsize, DC / DC power supplies lead the industry with the lowest ripple available for their package size. While they are industry standard products, the PMT Series' performance versus cost makes them an exceptional value. In addition, their incredibly small footprint makes them perfect for size critical projects. Countless applications include photomultipliers, ionizers, and various electrostatic solutions.

PMT Series standard models offer inputs up to 24V and outputs of up to 1.5 kV and 1 W. Custom versions are also available with minimal lead time and low production cost.

**IN STOCK TODAY! Contact us for a quote or to place your order!**

**APEC 2017**

Visit us in Booth # 1427



PRODUCTS BY:  
**DEAN**  
TECHNOLOGY

[www.deantechnology.com](http://www.deantechnology.com)

These systems normally incorporate a system control module that's essentially a single-board computer (SBC). The SBC can run a standard operating system like Linux or Windows along with applications written using test-and-measurement tools, such as NI's LabVIEW. These systems could tie into another computer that may provide a graphical interface.

Many vendors provide chassis, control modules, and data-acquisition modules for a complete solution. It's usually pos-

sible to mix-and-match modules as well.

Keysight Technologies' M9005A is a 5-slot, 3U PXI Express chassis with a built-in system control module. Two slots are for PXIe cards and the other three are hybrid PXIe slots. A hybrid slot can handle parallel bus PXI/PCI and PCI Express PXIe cards. The system doesn't include a PXIe timing slot.

Data-acquisition cards like ADLINK Technology's PXIe3-9848 (Fig. 1g) is an eight-channel PXI Express capture board.


Its 14-bit ADC has a 100-Msample/s sample rate and can handle a 100-MHz input bandwidth. The board has 512 MB of storage with scatter-gather DMA data-transfer support for high-speed data streaming. As you might guess, this board is more likely to be used for high-speed signal-conditioning applications like radar systems or power-supply testing applications.

### NETWORKING SCOPES

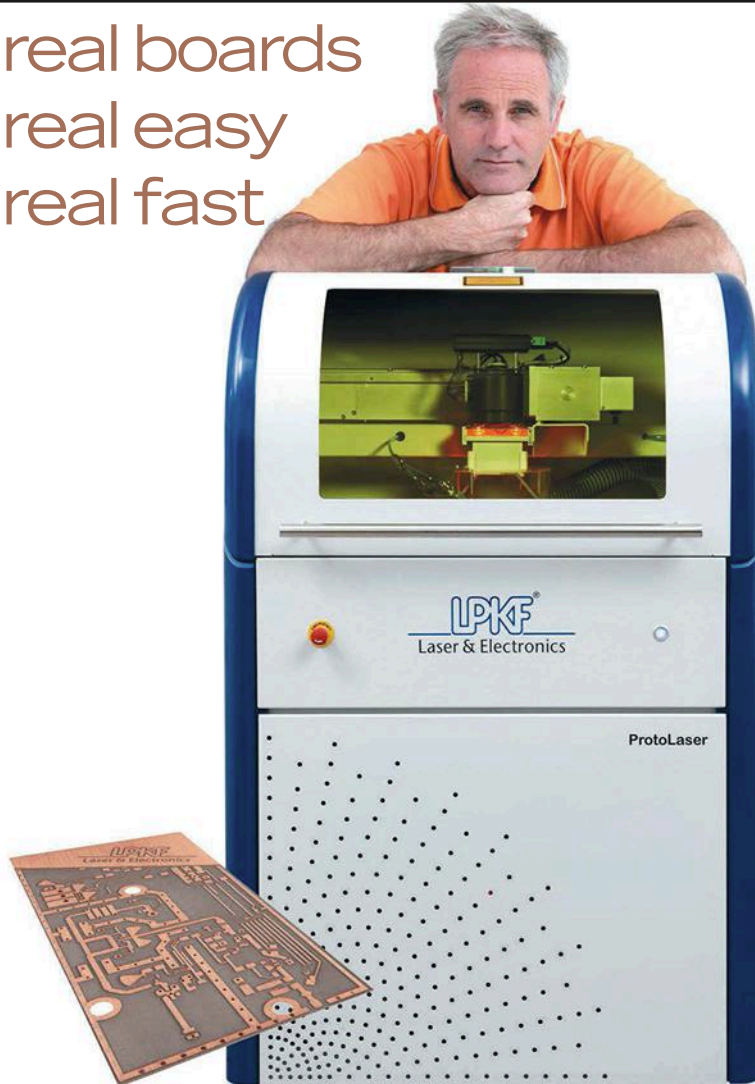
It's almost a trivial exercise to link a PC to Wi-Fi or Ethernet. These days, the same is true for many oscilloscopes, since they're essentially specially built PCs. Network support has a number of advantages, depending on what services may be supported by the scope. This might include data-transfer options to remote-control operation. It all hinges on the support provided by the vendor.

Some systems support APIs or have links with development tools like MathWorks' MATLAB or LabVIEW. This allows developers to create custom test and control applications that can tie the oscilloscope to other networked equipment and software.

Users will need to consider tradeoffs between networking a conventional oscilloscope and a custom system like one based on Keysight's M9005A. Security and reliability issues should also be considered, along with functionality.

Oscilloscopes are still used to track analog signals, but these days they can do much more. They can communicate with other systems and they may even wind up controlled by apps running on smartphones and tablets. The Tektronix 531 is unlikely to be on the list of supported scopes, but quite a few newer oscilloscopes may find their way onto it. 

real boards  
real easy  
real fast



### ProtoLaser. It's the real deal.

Design your circuit, load virtually any type of substrate, send your file, and you'll have real working circuit boards in minutes. So real in fact, you'll achieve consistent, high resolution geometries that chemical etching can't even touch. From prototypes to medium-run production, the ProtoLaser will liberate you from the board house.

[www.lpkfusa.com/pls](http://www.lpkfusa.com/pls) • 1-800-345-LPKF

**LPKF**  
Laser & Electronics

# Take the Easy Test Road (Sometimes)

Getting the job done right means making design tradeoffs and spending your time wisely—sometimes you can save time by taking the easy road, sometimes not.

Get it—life in the lab isn't leisurely. Impending deadlines and unexpected time sinks always seem to pull you away from what you need to be doing. And, in the test-and-measurement field, we spend a lot of time telling you how to make the highest-quality measurement or how to test your device to the most stringent possible specifications. Today I'm going to sing a different tune. Sometimes, you can take the easy road and still get your job done.

Your testing with an oscilloscope will fall into one of two categories: qualitative testing and quantitative testing. Knowing which type of testing you're doing will inform how you spend your time in the lab (Fig. 1).



1. Balancing time and thoroughness in the lab can be difficult.

## QUALITATIVE VS. QUANTITATIVE MEASUREMENTS

*Qualitative testing—think “qualify”*

Qualitative testing is the off-the-cuff testing that you typically do when you're debugging a design or

poking around your board with probes to make sure everything's working. Think “qualify” as functional or not. You don't care so much about getting a great connection to your device or if your clock signal's rise time is 10 ns or 12 ns. You just want to make sure that the clock is actually functioning.

*Quantitative testing—think “quantify”*

Quantitative testing is the type of testing we love to talk about in the test-and-measurement industry. It usually leads to you drooling over some fancy new gear that falls into the “if you have to ask how much, it's too expensive” department.

However, that's not always the case. If you're doing quantitative testing it simply means that you care about the stats (think “quantify,” like stats/numbers). You *do* care about the difference between a 10-ns and 12-ns rise time because you need to hit the crucial “setup and hold” requirements of your receiver. Or, you care about the difference between a 5-V p-p signal and a 5.5-V p-p signal because your amplifiers might saturate.

So, before doing any testing of your device, you need to know which of these categories your work falls into. Once you know, you can evaluate the following considerations for yourself and decide how much they actually matter for the task at hand. Here are some pointers for things you should always do, sometimes do, and rarely do.

## WHAT YOU SHOULD ALWAYS DO

*Start from a known state*

You never know for sure what the person before you did to that poor oscilloscope (or what *you* were thinking the last time you used it). Save yourself a lot of trouble down the road and always start from a known state. Hit the “default setup” button, or better yet, load your own custom setup so that you're always starting from the same place.

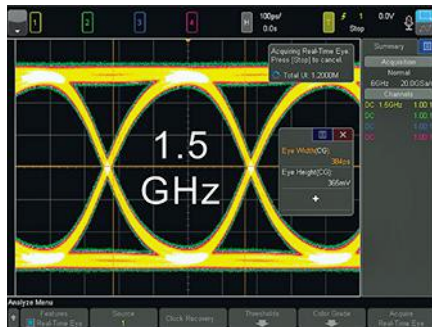
*Do a quick “spec check”*

Make sure the oscilloscope and probe you're using can handle the signals you're testing.

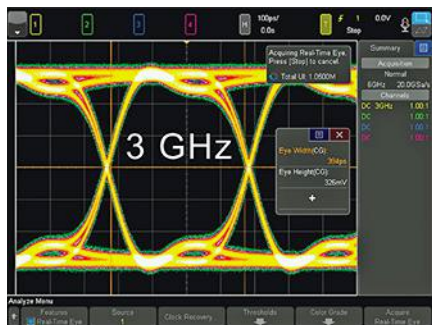
- **Bandwidth:** If you're looking at a 200-MHz square wave, your 200-MHz scope probably isn't the best choice. You could probably get away with it for qualitative testing, but what you

see on the screen will look nothing like your actual signal. The general rule of thumb is to make sure your system bandwidth is 5X your fastest digital signal and/or 3X your fastest analog signal.

Wait, did you see that? I said “system” bandwidth not “oscilloscope” bandwidth. As it turns out, your probe bandwidth and the method of connection both influence your test system’s bandwidth. Look near the end of the article “How to Pick the Right Oscilloscope Probe” for more info on how to calculate that. If you’re doing sensitive quantitative measurements, you want to be darn sure that you have ample system bandwidth or you’ll potentially get some misleading time-dependent measurements (Figs. 2-3).



2. A 1.2-GHz signal on an oscilloscope with a 1.5-GHz bandwidth.



3. The same 1.2-GHz signal on a 3-GHz-bandwidth. Notice the difference that bandwidth makes for your measurements.

- **Probes:** Always pick the right probes. It seems obvious, but the difference between a standard passive probe and a higher-end active probe is pretty significant. For qualitative testing, the standard passive probes included with the box are generally going to be fine assuming they deliver the needed bandwidth. But, for quantitative testing you really might want to consider something a little beefier. Probe specs like capacitive loading and device connectivity can dramatically affect your measurements. To learn more about probe specs you might want to consider, check out the article linked in the paragraph above.

**WHAT YOU SHOULD SOMETIMES DO**

*Calibrate your gear*

Is your test gear’s calibration up-to-date? If not, it’s probably not a big deal. But calibrated equipment does give you an assurance that your measurements are falling within a specified tolerance. If you’re doing qualitative testing, you will generally be able to debug your device without much trouble.



4. User calibration status is provided on a Keysight InfiniiVision 4000 X-Series oscilloscope.

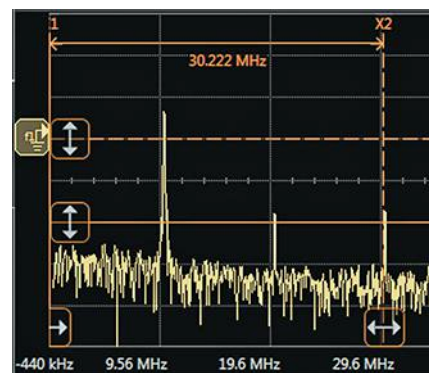
However, if you’re doing highly sensitive quantitative testing (like conformance testing or manufacturing-line testing), you want to use appropriately calibrated equipment. A number of different calibration certifications are out there, so make sure you choose the one that makes sense for your testing. Ultimately, if you have tight tolerances in your design, you want to make sure you’re not going to shoot yourself in the foot by being lazy with your equipment calibrations (Fig. 4).

*Turn off the lights (get out of a noisy environment)*

Don’t underestimate your environment. Some of the cubicles here at Keysight have a built-in fluorescent light below some shelving units. More than one engineer has been duped into thinking that their design has an unusual noise profile when it was simply the light injecting the noise. Think about what fans, lights, and other equipment might be injecting noise into your system. For qualitative testing, it usually won’t impact you, but for quantitative testing it could send you down the wrong debug path.

*Measure with cursors*

Sure, it’s much easier to just turn on the scope’s automated measurements. But, every once in a while, you’ll find a glitch or anomaly that doesn’t quite fit any of those cookie-cutter measurements, forcing you to dig deeper. This is true for both qualitative and quantitative testing; follow your gut on this one, but don’t get snagged down the road because you didn’t



5. On this Keysight Infinium S-Series oscilloscope, an FFT is measured with cursors.

explore that little ripple as much as you should have (Fig. 5).

### WHAT YOU RARELY NEED TO DO

You need only consider these things if you're doing quantitative testing. This could mean you're doing verification and diagnostics on your manufacturing line, trying to track progress on noise reduction efforts, or running application-specific compliance testing.

#### Measurement statistics

Getting statistics on your oscilloscope measurements is a great way to track progress throughout the course of a project. Statistics give you insight into the reliability of your design by providing averages and standard deviations, as well as alerting you to potential worst-case scenarios. Finding your system's bit error rate can be pretty useful, too. For best results, set up your measurements, start the testing, and go to lunch or that painfully long team meeting. When you come back, you'll have a strong sample size to evaluate (Fig. 6).

#### Mask testing


This is another good set-it-and-forget-it test scenario. Define a mask with acceptable tolerances. Go home for the evening or the weekend. When you come back, you should have a good idea of how reliable your system is, because you were able to run a few billion (or few trillion) tests.



6. Shown is standard deviation of a signal after 58,000 measurements on an InfiniVision 6000 X-Series oscilloscope.

### GETTING THE JOB DONE

Ultimately, you can read as many advice articles as you want, but at the end of the day, you have to get your job done right. This means making tradeoffs in your design and in how you spend your test time. Sometimes you can save time by taking the easy road, and sometimes you can't.

This list is by no means comprehensive, but it should give you some food for thought the next time you don your lab coat. Happy testing! 

# In PoE/PoE+ applications where cost, power and space are critical

Proudly Distributed out of Austin, Texas by:



[www.keiconn.com](http://www.keiconn.com)

800-325-0534

We'd love to meet with you at APEC!

- 10/100Base-TX PoE/PoE+ products in standard and extended temp ranges
- Gigabit PoE/PoE+ products in standard and extended temp ranges
- Ask about Halo's PROPRIETARY PoE++ Solutions
- PoE Flyback Transformers designed for DC/DC converter circuits



**HALO**  
ELECTRONICS, INC.



# Everything You Need to Know About the New PoE Standard

Due to the increased number of Ethernet-connected devices demanding more power, a new IEEE 802.3bt standard is on the way.

As Power over Ethernet (PoE) continues to grow in popularity, so does the demand for applications with higher power. The current standard, IEEE 802.3at, allows for maximum power at the powered device (PD) of 25.5 W, while the upcoming standard will allow maximum power of up to 90 W.

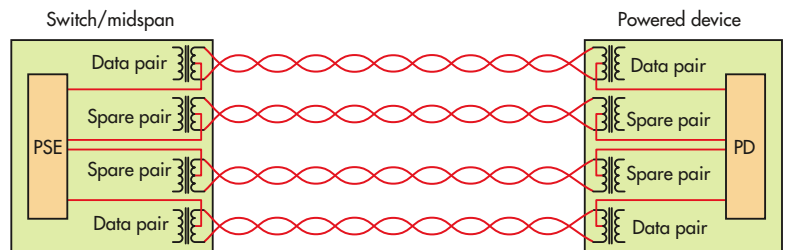
## WHAT'S IMPROVED?

The new standard will increase the maximum PoE power by using all four pairs of the wires being useful for applications where more power is required, such as pan-tilt-zoom (PTZ) cameras, VoIP phones, security-card readers, LED lighting, and point of sale (Fig. 1).

“This not only enables the new higher power level, but also provides better efficiency for the current PoE power levels,” says Jeff Heath, PoE product line manager for Linear Technology. “The power loss in the cable is cut in about half. For example, an IEEE 802.3at PSE (power sourcing equipment) is required to supply a minimum of 30 W to ensure that the PD will receive 25.5 W. In the IEEE 802.3at standard, as much as 4.5 W is lost in the CAT5 cable.

“Powering the same 25.5 W with the IEEE 802.3bt standard will cut the loss to less than 2.25 W,” he continues. “This increases the power-delivery efficiency from ~85% to ~92%. When you consider the number of PoE-powered devices in the world, this translates to very large reduction in power, and in many cases up to a 7% lower carbon footprint for areas that are powered by fossil fuel.”

The new standard will define two more types of PSEs and



1. All four pairs are used to deliver power in an IEEE 802.3bt PoE system. (Courtesy of Microsemi)

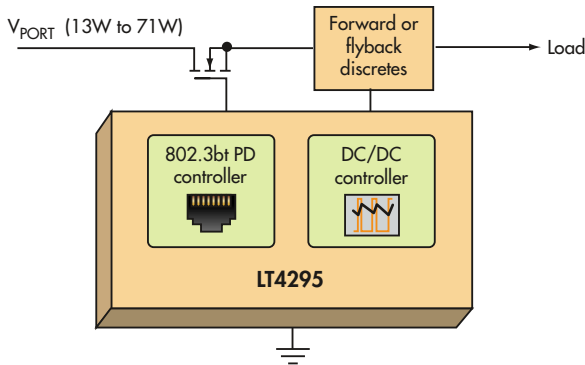
PDs—Types 3 and 4. These additions will increase the maximum PoE power by delivering more power through two or more pairs of Ethernet cables.

PD type	PD power	Cable category	Classes
Type 3	40-51W	Cat5e	4 pairs class 5-6
Type 4	62-71W	Cat5e	4 pairs class 7-8

A new physical-layer classification, autoclass, will help the PSE determine the actual maximum power drawn by the connected PD. Type 3 and 4 PSEs will identify the PD and set the power accordingly to the maximum PD power, resulting in a better power-delivery system.

To maintain a PSE power, a PD must generate a power signature while the lights are off and data communication remains active. The new standard will reduce the time duration and the Maintain Power Signature (MPS) duty cycle to reduce the average standby power/current, benefiting applications such as LED lighting due to the high number of ports.





2. The LT4295 supports both forward and flyback power-supply topologies. (Courtesy of Linear Technology)

“The IEEE 802.3at standard required ~0.13 W to be consumed by a PD,” explains Heath. “If the PD fell below this power level, the PSE would turn off power completely. The new IEEE 802.3bt standard allows a much lower power for the standby level. Only ~0.02 W is required to maintain a power connection. This allows PoE to power ‘green’ applications with agency requirements for low standby power.”

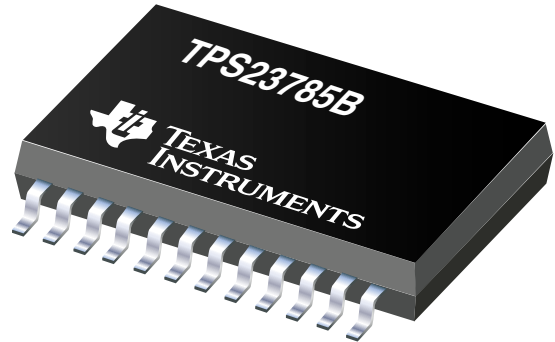
### THE PoE MARKET TODAY

Even though IEEE802.3bt has yet to be ratified, high-powered PoE products are already available on the market today, while the PoE market will expand with the addition of new applications. Here are some of the latest innovations currently available:

#### PD Controllers

Linear Technology already offers the first IEEE 802.3bt-compliant (Draft 2.0) PD interface controller, the LT4295 (Fig. 2). The new device eases migration of LTPoE ++ PDs to IEEE 803.3bt PDs, and supports up to 71 W (input) at PDs. It features an external MOSFET for better control of heat dissipation and power efficiency. The new IEEE 802.3bt defines two PD topologies—single-signature and dual-signature—but the LT4295 primarily targets single-signature PD topologies that could be used for simpler and cost-effective designs. The LT4295 is offered in industrial and automotive grades; it can also be used in applications such as outdoor security-camera equipment, commercial and public information displays, etc.

Texas Instruments developed a highly efficient PoE PD interface and dc-dc controller that powers up to 30 W (input) at PDs, and it complies with IEEE802.3at. The TPS23785B (Fig. 3) features a detection signature pin that can be used

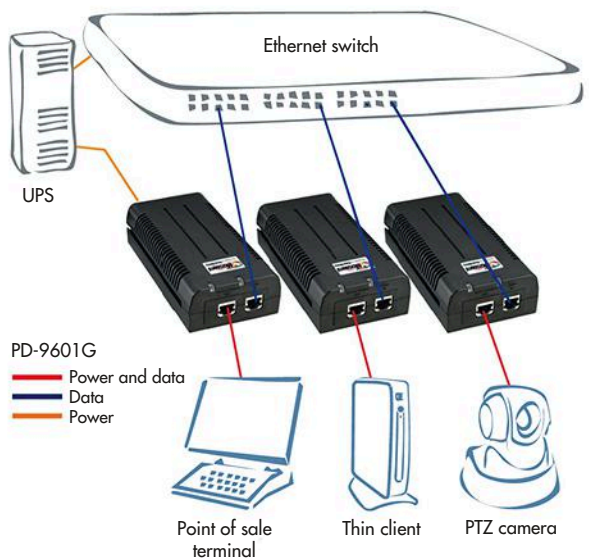


3. The TPS23785B supports forced operation from either a wall adapter or PoE power. (Courtesy of Texas Instruments)

to force power from the PoE source to turn off. It also supports a number of input voltages, allowing the designer to determine which power source will carry the load under all conditions. This device can be used in designs for powering IP network cameras where energy efficiency is a significant factor.

#### Power Sourcing Equipment

Microsemi offers a single-port Gigabit Midspan solution, the PD-9601G (Fig. 4), for remote powering of current transmitting up to 95 W of power over 4-pairs, reducing cable losses. This midspan is able to power high-power applications



4. The 9601G maintains a voltage of 54 to 57 V and maximum output power of 95 W. (Courtesy of Texas Microsemi)

According to a research report by MarketsandMarkets, the PoE market is expected to grow and reach more than \$1 billion by 2022. The PoE market will expand with the new standard, giving way to higher-power solutions.

such as VoIP phones and IP cameras, and it complies with IEEE 802.3at and 802.3af.

*PSE Controllers*

Maxim Integrated has a solution for network equipment. The MAX5965A (Fig. 5) is a monolithic PSE controller for PoE that has been designed to meet IEEE 802.3at, delivering up to 45 W per port for high-power PSE applications. It also provides high-capacitance detection for legacy PDs.

**THE FUTURE OF PoE**

According to a research report by MarketsandMarkets, the PoE market is expected to grow and reach more than \$1 billion by 2022. The PoE market will expand with the new standard, giving way to higher-power solutions.

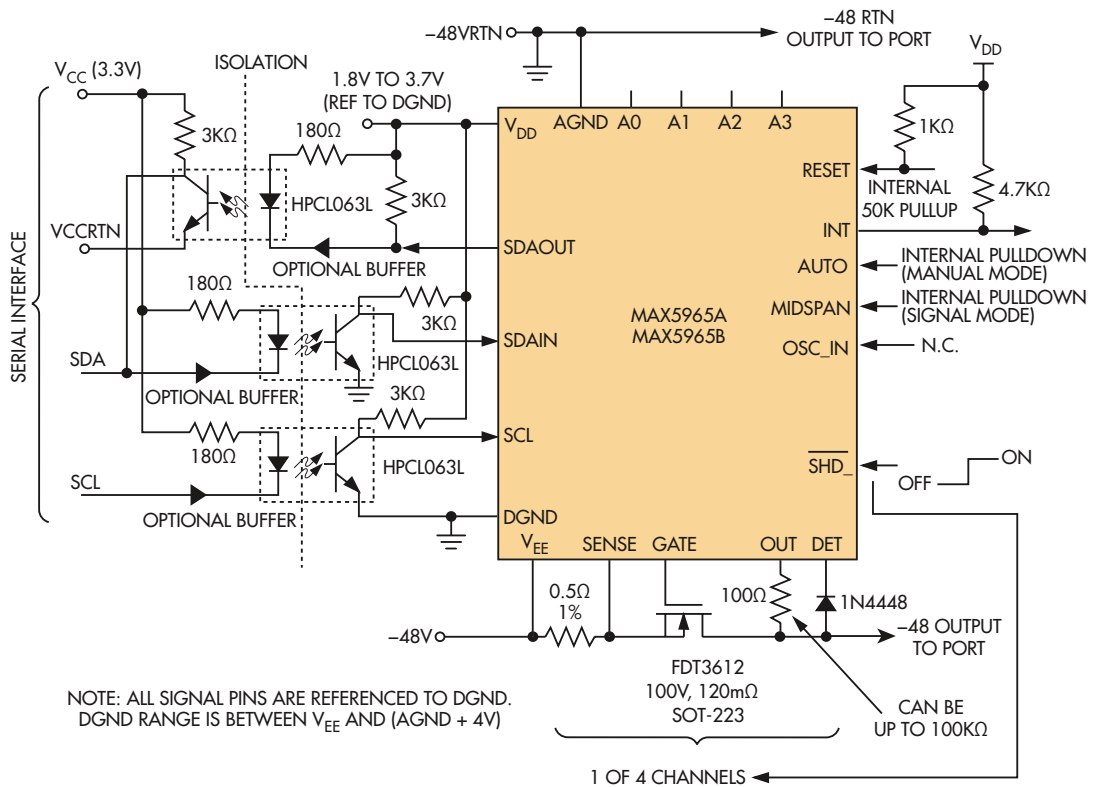
“Technically speaking, the new standard will allow for more power (60 and 90 W sourced), enhanced system efficiency,

and better optimization of system power allocation,” says Jean Picard, senior member technical staff at Texas Instruments. “From a market point of view, the standard opens new markets that were not previously accessible. One example is PoE lighting.

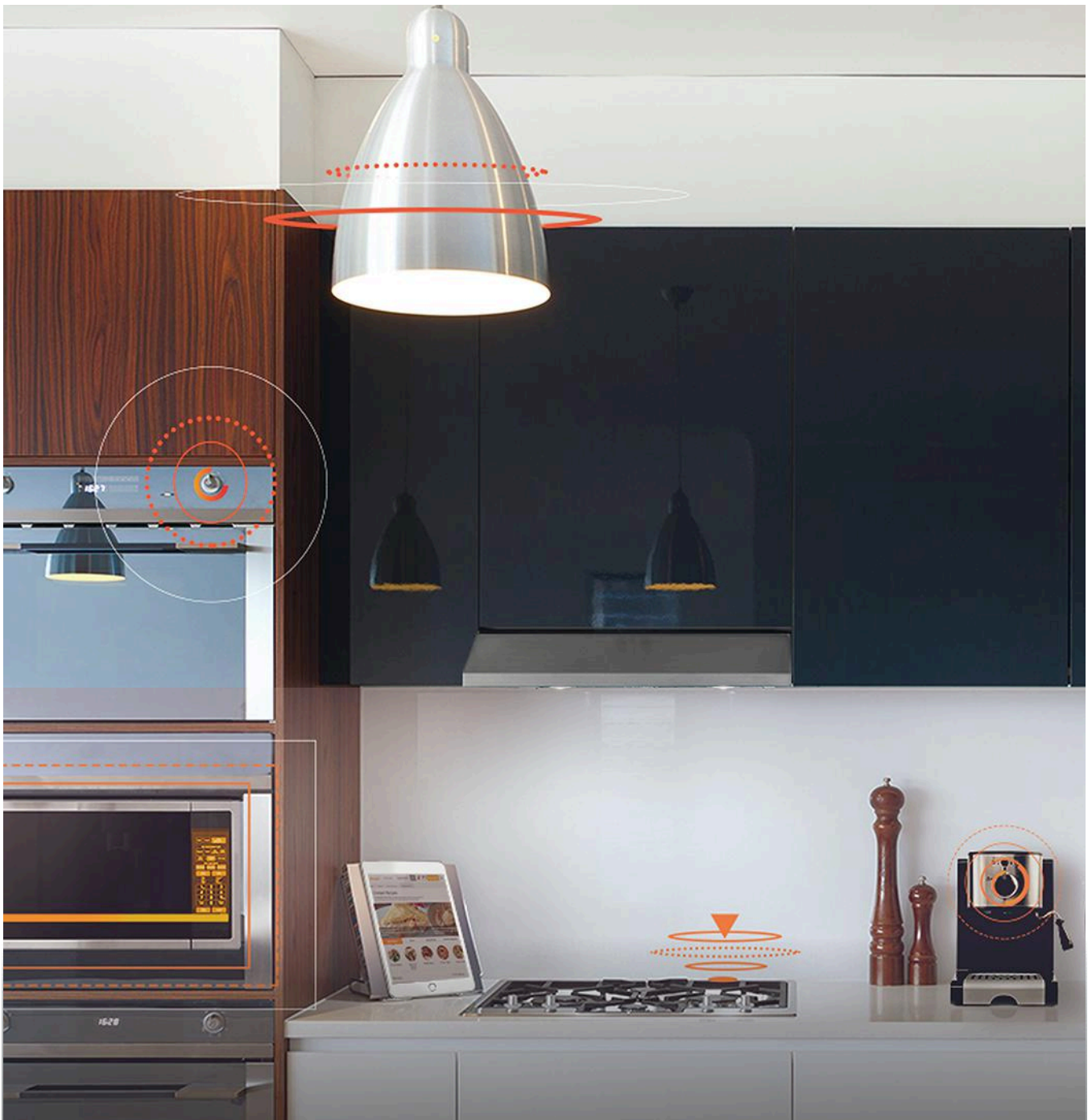
“There will be an emergence of so-called ‘connected lighting systems,’” he continues, “which will deliver illumination experience well beyond basic lighting control.”

“For the LED lighting market, the new PoE standard will provide much brighter light fixtures,” adds Linear Technology’s Heath. “But perhaps more importantly, it will allow the individual lights to meet the ‘green’ power requirements while in a standby state (e.g., lights off).”

Players in the semiconductor, lighting, and IT industries will continue working on better, higher-power solutions to use with the new standard, IEEE 802.3bt.



5. The MAX5965A provides four operating modes to suit different system requirements: automatic, semi-automatic, manual, and shutdown. (Courtesy of Maxim Integrated)



# CONNECTIVITY FOR THE HOME

TE Connectivity (TE) is creating the connector and sensor solutions that make connected homes a reality. From smart thermostats to connected appliances, TE's unrivaled portfolio and global manufacturing capabilities can help you turn the wildest ideas into the smartest ways of life.

Innovation for the connected home starts here. [te.com/connectedhome](http://te.com/connectedhome)

©2017 TE Connectivity Ltd. All Rights Reserved. EVERY CONNECTION COUNTS, TE, TE Connectivity and TE connectivity (logo) are trademarks of the TE Connectivity Ltd. family of companies.

EVERY CONNECTION COUNTS





# Will PMIC On-Demand Replace Catalog Power Devices?

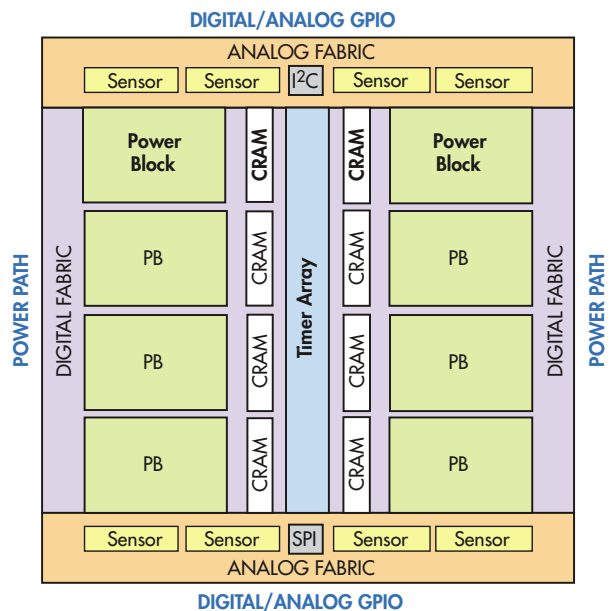
There is a new trend to customize power-management integrated circuits on-demand using interconnected power blocks, adding flexibility, and potentially disrupting the power device business.

**M**ost consumer electronics products rely on power-management integrated circuits (PMICs). As those consumer devices evolve, designers face the constant challenge of trying to reduce board footprint and decrease power consumption. Over the years, programmable analog devices like field-programmable analog arrays (FPAAs) have been used very successfully.

Now, a new developer called AnDAPT is paving the way toward customized, integrated power-management solutions. I think AnDAPT's AmP technology will disrupt the power-management semiconductor market, as AnDAPT offers programmable solutions with analog proficiency to customers producing units at any volume. I also asked another expert to weigh in on this new technology and the reasons for potentially disrupting the PMIC market.

AnDAPT claims that its on-demand power-management technology can be configured exactly to the power characteristics of a particular system without worrying about analog issues, such as varying interface voltage, interface current, noise, and impedance matching. Its solutions use analog power blocks with scalable integrated MOSFETs (SIMs) to increase current capabilities. These analog power blocks are called Adaptive Multi-Rail Power (AmP) platform ICs; they are interconnected with digital circuitry in a way comparable to field-programmable gate arrays (FPGAs). Because of the digital interconnect fabric, AmP platform ICs can be configured precisely to the power characteristics of a particular system.

AnDAPT's solutions are not only available for enterprise solutions with high shipment volume, but also relatively low-



Shown is the Adaptive Multi-Rail Power platform for an AmP8DS6 with eight power blocks. (Courtesy of AnDAPT)

volume end products like medical devices and PCs. AmP platform ICs can substitute power-management devices, such as buck regulators, boost regulators, low-drop-out regulators, load switches, controllers, etc.

“Fundamentally, AmP platforms implement most functions in analog ( $\mu$ Analog) implementation as is done in analog catalog devices. Therefore, they have similar performance characteristics as custom analog designs,” says AnDAPT's president and CEO, Kapil Shankar.

“For example,” he adds, “we do not require a faster digital clock, as most ASIC digital power implementations do. Therefore, our bias currents are in the very low tens of microamps range, delivering us some of the best peak efficiency performance (e.g., our peak efficiency numbers are close to 95% for 6.0- to 3.3-V conversions). Our process MOSFET figure of merit is 75 nC\*mΩ, which is in line with the best in our industry.”

The AmP devices are supported by the WebAmP development software, which is cloud-based. The inclusion of more analog functions and capabilities can be handled with Verilog code. Users can drag-and-drop power components from the pre-built library based on their application rail requirements. For an example, take a look at AmP8DS6 platform to see how you can drag-and-drop components (Fig. 1). AnDAPT’s first devices are part of a 12-V family of nine members with three selections: four, eight, and 12 power blocks of 1-, 3-, and 6-A current capacity each (Fig. 2).








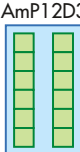

AmP devices can provide telemetry via built-in PMBus over I<sup>2</sup>C. In addition, the serial peripheral interface (SPI) can be used for device configuration. Users can also run power analysis to optimize an AmP design by using the LC calculator, stability analyzer, PID tuning, transient response calculator, etc.

Shankar notes, “Additionally, we undertake the same level of testing as our competitors. And even though we have a different architecture, we benchmark ourselves based on industry-accepted performance metrics regarding efficiency, dynamic performance, and static performance. We have also already passed extensive VRD testing at the top data-center processor vendor.

“All vendors have their own certification testing classified in five areas of regulation, transient response, startup, shutdown, and protection testing,” says Shankar. “We have ourselves conducted extensive testing for our power components in each of these areas. We implement telemetry using the standard PMBus standard. We will also look at standards such as DOSA over time as we develop our technology further.”

In the future, AnDAPT will include the AmP 60-V family supporting an input voltage from 24 to 60 V, the AmP 5-V family supporting an input voltage from 1.8 to 9 V, and the AmP 110-V family supporting an input voltage of 110 V. Also, AnDAPT is expecting to complete ISO90001 by Q2 next year.

“The certifications are usually done by our end customers,” says Shankar, “but we do undertake silicon qualification using processes accepted in the industry. Qualification for the technology, product platform, and package is done with standard

AmP 12V Power Blocks	1A	3A	6A
Four	AmP4D1 	AmP4D3 	AmP4D6 
Eight	AmP8D1 	AmP8D3 	AmP8D6 
Twelve	AmP12D1 	AmP12D3 	AmP12D6 

**This is AnDAPT’s first 12-V family; AnDAPT plans to include two more families in the near future (60 V and 5 V) to cover the Automotive and IoT markets. (Courtesy of AnDAPT)**

testing for HTOL, high-temp cycling, HAST, high-temp storage, ESD, latch-up, etc. We expect qual completion in the first quarter of 2017.”

AnDAPT is not the first company that’s digitizing power analog devices. Companies like Silego and Anadigm offer not only power-management solutions, but mixed-signal solutions and more. But I think AnDAPT’s AmP technology will disrupt the power-management semiconductor market, as AnDAPT offers programmable solutions with analog proficiency to customers producing units at any volume. Such an approach certainly can aid in saving time, reducing board footprint, and lowering costs.

Richard Wawrzyniak, principal analyst, Semico Research Corp., notes the reasons for this trend:

“It is well known that the need to fill data centers with multiple processors, more storage, and higher-performance networking is ever increasing. These needs push against constraints imposed by power costs and more importantly pre-existing power frameworks. The primary driver for this solution, therefore, is the need for control, telemetry, and management of power delivered/consumed by every processor, logic, memory, and storage device and, therefore, every silicon device in a data center.

“The existing solutions rely on a majority of discrete power devices with a limited or very low cost-effective power-management capability. In other words, no custom PMICs are available, as the rail requirements are too diverse and limited opportunities exist for volume aggregation

“The AnDAPT solution allows for a consolidation in the number of different discrete PMIC solutions a designer must deal with in his approach to creating and distributing a multitude of power rails around his system.” —Richard Wawrzyniak, principal analyst, Semico Research Corp.

**42 Thousand Servers.**  
**21 Megawatts of Power.**  
**Zero Margin of Error.**

When you're managing a datacenter that draws more power than a small city, you can't afford a meltdown. At Positronic, we build high reliability, power-efficient connectors. But our true call is to provide certainty. Rock solid, mission-critical performance upon which you can bank life and limb, family and fortune. We consider it an honor. We consider it an inviolable trust.

POSITRONIC. THE SCIENCE OF CERTAINTY. / [www.connectpositronic.com/ed](http://www.connectpositronic.com/ed)



Positronic®

to amortize custom PMIC NRE. The AnDAPT solution, because it is an off-the-shelf solution, offers an ability to build a cost-effective custom PMIC for all these silicon types, regardless of volume, enabling the ability to provide management capabilities and lower power consumption.

“The AnDAPT solutions also deliver lower cost compared to discrete POLs, integration for smaller board footprint to make space for other components, and lower inventory costs for 12-V dc-dc stepdown regulator applications. AnDAPT’s roadmap shows future direction to include 48- to 60-V multi-rail power (AmP) platforms, enabling the same benefits for intermediate-rail 48-V dc-dc stepdown regulators’ applications.”

Wawrzyniak concludes, “The AnDAPT solution allows for a consolidation in the number of different discrete PMIC solutions a designer must deal with in his approach to creating and distributing a multitude of power rails around his system. Since the AnDAPT devices are programmable, a single device type can stand in for many different discrete types of PMICs and still meet the designer’s requirements. This in turn reduces the number of different part types a designer must deal with and reduces inventory costs and delivery times. In essence, designers can have a custom solution for very close to the cost of an off-the-shelf part with all the flexibility that comes from such a technology—a very powerful combination in today’s marketplace.”

Do you think AnDAPT’s  $\mu$ Analog devices could perform as well as analog power components?

# COM Express Modules Handle 10 G Ethernet

The latest computer-on-module (COM) technology includes platforms that are pushing 10 Gbit/s Ethernet.

**P**ICMG's COM Express standard has garnered quite a following. The standard encompasses a range of board sizes and features: Basic size module is 125 mm by 99 mm, while the Mini is only 84 mm by 55 mm. In between is a 95 mm by 95 mm Compact and a larger 110 mm by 155 mm Extended version.

The COM approach allows simplified carrier board designs to host different modules depending upon system requirements. It also provides an upgrade path as newer modules are released. Carrier boards are for the most part significantly easier to design and less expensive than the modules that have the high-performance parts, such as the processor and memory. The COM Express interface exposes most interfaces, with the exception of memory.

COM Express modules have connectors for a carrier board on one side and often have sockets for memory, as the connectors to the base board are normally reserved for interface signals including Ethernet networking and PCI Express. The COM Express Type indicates the connector and interfaces provided. Common types include Type 2, 6, 7, and 10.

ADLINK Technology's Express-BD7 (*Fig. 1*) is a Type 7 COM Express module that supports x16 PCI Express Gen 3, eight x1 PCI Express Gen 2, and two 10 Gbit/s Ethernet interfaces with NC-SI support. There is an additional gigabit Ethernet port, two SATA 6 Gbit/s ports, and four USB 3.0/2.0 ports. The module has an Intel Xeon D with up to 16 cores and up to 32 Gbytes of DDR4 with ECC in a pair of SODIMM sockets. The system supports ADLINK's Smart Embedded Management Agent (SEMA).

The Express-BD7 is one of the larger COM Express form factors, but it is still possible to fit 10 into a 1U box. Of course, it could use its own switch since it would have 20 10 Gigabit Ethernet connections and 10 Gigabit Ethernet connections.

Most applications will likely use a single Express-BD7.



**1. ADLINK's Express-BD7 is a Type 7 COM Express board that exposes a 10 Gbit/s Ethernet interface.**

The 65 W TDP per module minimizes cooling requirements. Note that this module does not provide video output as it is designed as a compute and networking solution.

COM Express modules can be used with custom carrier boards, but they have also been useful in providing standard platforms. This provides vendors with a module solution while reducing the number of systems.

Diamond Systems uses a COM Express module in its Vega EmbeddedXpress (EMX) form-factor system (*Fig. 2*). The Vega can also be found inside Diamond Systems' rugged Raptor-Vega enclosure system.


The top Vega layer is actually the carrier board with the exposed peripheral interfaces. The carrier also has a Mini-PCIe socket for expansion (see "PCI Express Mini Card Tackles Compact Embedded Expansion" on [electronicdesign.com](http://electronicdesign.com)). In addition, the socket supports mSATA storage. There is an EMX bus connector for additional board expansion.

The bottom of the stack is a heat spreader for the 95 mm by 125 mm COM Express board in the middle. The COM Express boards have a 1.7 GHz Intel Core i7-3517UE or a 2.1 GHz Intel Core i7-3612QE processor. They have up to 8 Gbytes of DDR3 SDRAM in an SO-DIMM package. There are also two Gigabit Ethernet ports, a SATA port, four USB 2.0 ports, and four RS-232/422/485 serial ports, plus VGA/LVDS video outputs and HD audio support. The system also sports 16-bit ADC and DAC, digital I/O, and counter/timers. It runs Windows and Linux.



COM Express is only one of many computer-on-module (COM) form factors. Another common COM form factor is SMARC (see "11 Myths About SMARC 2.0" on [electronicdesign.com](http://electronicdesign.com)). SMARC comes in a full-size 82 mm by 80 mm version and a short 80s mm by 50 mm module.

2. Diamond Systems' Vega is an EMX form factor that hosts a COM Express board to provide processing options.

COM's popularity continues to increase among designers and developers. It provides flexible scaling options while reducing custom design costs. Smaller modules even work in portable applications. 

## IXIDM1401- 10A/4000V Isolated Gate Driver Module AC, DC motor drives, inverters, converters, medical, UPS, traction and SMPS

### Key Features:

- Dual Channel Driver for Half-Bridge Switching Modules
- Blocking voltages up to 4000 V
- +15 V/-5 V Isolated Gate Driver Output Voltage to Drive IGBTs with up to 10 A Pulse Current
- 3 V TTL Logic Level Microcontroller Interface
- Single 15 V Power Supply Operations
- Operating Ambient Temperature: -40°C~+105°C
- Footprint: 50 mm x 50 mm
- UVLO, OVLO, OC, Temperature, short-circuit (SC), Active clamping protections (check datasheet for details)

### Optimized for:

Phase-leg IGBT Modules:

- up to 600A/600V • up to 600A/1200V • up to 450A/1700V

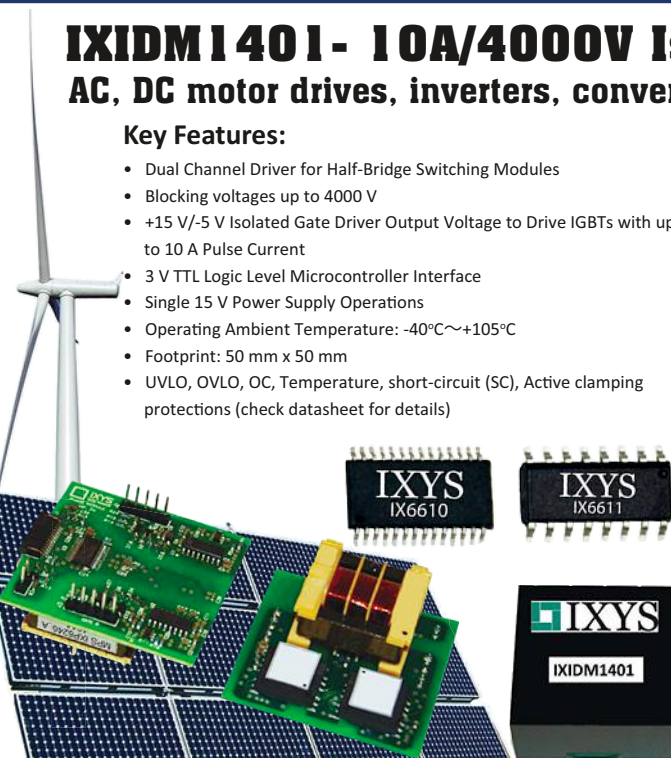
### 4. ORDERING INFORMATION

IXIDM①②③④\_⑤⑥⑦⑧\_⑨

DESIGNATORS	DESCRIPTION	SYMBOL	DESCRIPTION
①	Module Configuration	1	Two Isolated Gate Drivers
②③	Isolation Voltage	40	4.0 kV
④	Gate Current	1	10 A
⑤⑥	Positive Gate Voltage	15	15 V
⑦⑧	Negative Gate Voltage	05	-5 V
⑦⑧	Negative Gate Voltage	15	-15 V
⑨	Package Information		O – Open Frame, M - Molded

### PART NUMBERS AND ORDERING OPTIONS:

- IXIDM1401\_1505\_O - two isolated gate drivers with 10 A gate current, 15 V positive and -5 V negative gate voltage, open frame version.
- IXIDM1401\_1505\_M - two isolated gate drivers with 10 A gate current, 15 V positive and -5 V negative gate voltage, molded version.
- IXIDM1401\_1515\_O - two isolated gate drivers with 10 A gate current, 15 V positive and -15 V negative gate voltage, open frame version.
- IXIDM1401\_1515\_M - two isolated gate drivers with 10 A gate current, 15 V positive and -15 V negative gate voltage, molded version.







# WIRELESS POWER Prepares to Hit the Mainstream

Fueled by strong opinions from consumers about how devices should charge, wireless-power companies are looking to make wireless charging more accessible while providing “must-have” features.

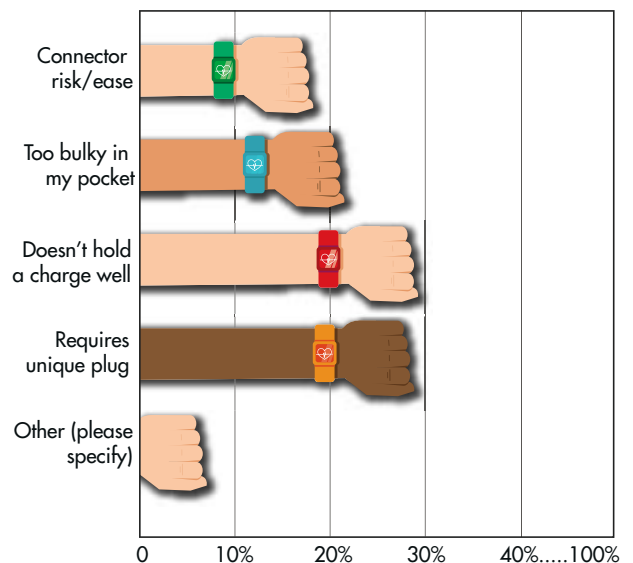
The growth in awareness and adoption of wireless-charging technologies is quickly climbing. To keep moving forward, suppliers must understand the needs of the consumers in order to develop and launch better products. A survey on wireless power commissioned by the AirFuel Alliance and several of its members (e.g., WiTricity and Energous) looked into consumer perspectives on wireless-charging technology. Among the highlights:

- 71% want wireless charging in their next device, and they are willing to pay for it in public spaces.
- 72% say wireless-charging capabilities are important to them, and 62% of those individuals say speed of charge is also critical.
- 49% don't even want to think about plugging in their smartphone or putting devices in a precise position to charge; they just want it to happen.
- 93% think wireless charging will become the new norm over the next three years.

After looking at the survey's results, it is clear that customers want wireless charging throughout their connected lives—at home, at work, and even when traveling. Ideally, they'd like to get rid of all cords and the different charging ports needed for every device they own. Looking at *Fig. 1*, it's clear that there are two main challenges to address: the unique plug and longer battery life.

The issue of longer battery life is related to battery anxiety, which is rather common. According to the survey, 45% of consumers report that they worry about losing the battery's charge a few times a day. And almost all users of portable-

WHAT ARE THE BIGGEST DESIGN CHALLENGES WITH YOUR CURRENT SMARTPHONE/WEARABLE DEVICES?



1. The two biggest wireless-charging design challenges are battery life and unique plugs. (Courtesy of the AirFuel Alliance)

power devices are concerned about their battery dying. This anxiety might be eliminated by making wireless fast-charging solutions easy to access in public spaces—especially since people are willing to pay for this capability.

Wireless charging also encourages a more reliable design, as charging ports allow dust and water to enter. In addition, their connector failures are often associated with design challenges (*Fig. 1, again*). By eliminating these ports, it saves consumers from having to carry different type of cables or plugs when they are on the go.

“We are surrounded by devices that must be juiced up periodically, be it plugging in our laptops at work or our phones when we go to sleep, requiring us to bring cords wherever we go,” says Sanjay Gupta, VP of product management for WiTricity. “Plugging in is not a natural human behavior, and consumers continue to demand freedom from wires and the ability to charge our electronics without putting thought to it.

“Just think—everything has become wireless except for the power cord itself,” continues Gupta. “Even autonomous devices, like drones, robots, or AGVs, are not truly autonomous until the cord is gone and humans are not required to charge them up. We are bringing our vision of a future where zero devices need to be tethered to a wall to a reality. Charging cords and power bricks will go the way of the rotary phone.”

Some of the challenges associated with wireless-charging technologies are related to the lack of a wireless-charging speed close to a wired-charging speed, constraints of spatial freedom, and power efficiency. At the moment, the more common wireless-charging technologies are:

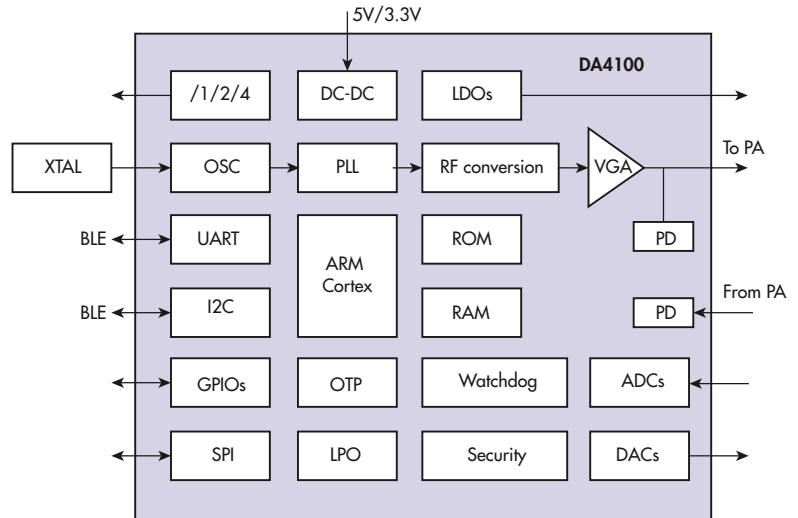
- Resonance technology
- Inductive technology
- Radio-frequency-charging technology

Even though resonance technology isn’t new, its next generation is trying to give more spatial freedom to consumers. With this technology, a resonant copper coil can transfer energy to a second resonant copper coil oscillating at the same frequency. It also uses loosely coupled coils that eliminate the need for perfect alignment.

Companies like WiTricity are using resonant technology at higher frequencies (e.g., 6.8 MHz) to transfer power over distances that currently work well with metal housings, because at higher frequencies wavelengths are much smaller and can travel through certain materials. This enables wireless power transfer deeper into structures like desktops and coffee tables.

For inductive technology, coils must be perfectly aligned to make the connection to transfer power. It is commonly found on direct-contact applications that need to be closely coupled (e.g., the Apple Watch).

Radio-frequency-charging technology does not use coils, instead employing RF receivers and transmitters. The technology is often compared to Wi-Fi, and works by sending out RF waves from a charging station using multiple miniature antenna arrays. It claims to have the potential to transmit energy even up to distances of 15 ft.



2. The DA4100 features an RF transmitter, power management, and integrated dc-dc converter to power Dialog’s external Bluetooth Low Energy ICs. (Courtesy of Dialog Semiconductor)

Wireless-power technologies are still maturing. They still face challenges in terms of transfer distance and power efficiency. In addition, the industry has yet to agree on a universal standard.

**STANDARD NEEDED**

Even though wireless-power technology is gaining traction, the lack of standards interoperability is hampering its growth. Meanwhile, IC vendors and ecosystem providers are increasingly offering multi-mode options to support standards like AirFuel and WPC, with transmitters oscillating at different frequencies (e.g., 100-200 kHz, 5.8 GHz, and 6.8 MHz).

“As consumer awareness of wireless charging continues to increase, they are demanding an experience where they can power up their devices no matter where they are, without precise alignment on a charging pad or giving charging any thought,” explains Gupta. “In order for that experience to exist, a universal standard must emerge so that all wireless-charging infrastructure (the devices, charging surfaces, value-added services, and their management) are interoperable.

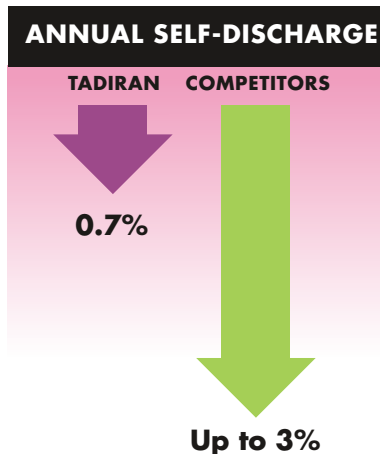
“WiTricity has committed to creation of global standards to ensure interoperability and is working with leading members of the ecosystem to create global standards for wireless charging of all devices,” he adds. “Wireless-charging standardization efforts in the automotive side are fast maturing. The SAE announced a new standard for wirelessly charged electric vehicles this past week.”

# No place to replace a battery.

PROVEN  
**40**  
YEAR  
OPERATING  
LIFE\*

## Highly remote locations call for Tadiran batteries.

Battery replacement is costly and often dangerous work. Reduce the risk with Tadiran bobbin-type lithium thionyl chloride ( $\text{LiSOCl}_2$ ) batteries. With an annual self-discharge rate of just 0.7% per year, Tadiran  $\text{LiSOCl}_2$  batteries enable low power consuming wireless devices to operate for up to 40 years on a single battery, up to 4 times longer than the competition. Our batteries also feature the highest capacity, highest energy density, and widest temperature range of any lithium cell, plus a glass-to-metal hermetic seal for added ruggedness and reliability in extreme environments.



Take no chances. Take Tadiran batteries that last a lifetime.



\* Tadiran  $\text{LiSOCl}_2$  batteries feature the lowest annual self-discharge rate of any competitive battery, less than 1% per year, enabling these batteries to operate over 40 years depending on device operating usage. However, this is not an expressed or implied warranty, as each application differs in terms of annual energy consumption and/or operating environment.

Tadiran Batteries  
2001 Marcus Ave.  
Suite 125E  
Lake Success,  
NY 11042  
1-800-537-1368  
516-621-4980

[www.tadiranbat.com](http://www.tadiranbat.com)

**W**ith better infrastructure and a universal standard, wireless-power technology will be widely adopted not only by the mobile industry, but others such as the automotive, military, and medical device spaces, to name a few.

Having looked at consumer views on wireless-charging technology, the types of technologies, and their challenges, let's look at some of the products in the laptop, automotive, and peripherals and wearables markets already leveraging wireless charging. Examples include:

### *RF-Transmit IC*

Dialog Semiconductor, in partnership with Energous Corp., offers the DA4100 WattUp Wireless Power Transmitter IC (Fig. 2). The IC, part of the Near Field WattUp transmitter system, is designed to charge a range of devices fitted with WattUp receivers. The chip features improved spatial and orientation freedom (WattUp technology can deliver power to multiple devices, in any orientation) and it operates directly from a 5- or 3.3-V power supply. Applications include the wireless charging of devices such as fitness bands, hearing aids, Bluetooth headsets, smart pens, and remote controls.

### *Laptops*

The new Dell Latitude 7285 laptop (Fig. 3) incorporates WiTricity's Magnetic Resonance technology. As an AirFuel-certified product, it will be interoperable with the emerging magnetic-resonance-based wireless-charging ecosystem developed by WiTricity.




**3. Laptops charge seamlessly when placed on a WiTricity charging pad.** (Courtesy of WiTricity)



**4. The Reserve Plugless Wireless Charger for Tesla Model S can charge at 7.2 kW.** (Courtesy of Plugless)

### *Automotive*

Wireless charging for electric vehicles is still in its infancy, but most carmakers are looking into the adoption of this technology in future vehicles. Carmakers had already started to offer wireless phone-charging technology as standard equipment or a factory option, but now we are also hearing about commercial applications for Wireless Electric Vehicle Charging (WEVC) systems. For example, a company called Plugless offers wireless-charging solutions for electric vehicles like Tesla (Fig. 4) and Chevy Volt.

As wireless-charging technology keeps evolving, we are seeing next generations of inductive and magnetic-resonance designs, and now RF wireless-charging technology designs. With better infrastructure and a universal standard, wireless-power technology will be widely adopted not only by the mobile industry, but others such as the automotive, military, and medical device spaces, to name a few. In the future, we may see applications using gallium nitride (GaN) due to its efficiency at higher frequencies. 

**NOTE:** SANJAY GUPTA will be a speaker at the ID&E show this May. If you would like to learn more about what wireless-power technology can offer, please register ([www.mfgtechshow.com](http://www.mfgtechshow.com)) and use the code IDEEARLY for a \$400 discount off of the current early-bird rate. This offer expires Feb. 28, 2017.



# Take a Practical Path Toward High-Performance Power Conversion

Integrated GaN Power IC building blocks enable fast-switching topologies with simple “digital-in, power-out” capability.

In power conversion, fast switching combined with high efficiency enables small size, low weight, and lower system cost.

To achieve this, we need to consider the choice of topology, power switch, and magnetic materials. Soft-switching techniques, coupled with novel gallium-nitride (GaN) power ICs and updated high-frequency-optimized transformers and inductors, offer a way to boost the efficiency and power density in ac-dc converters.

Traditional “hard-switching” topologies like quasi-resonant-flyback (QRF) or forward converters have loss in snubber networks and within the switching devices that cannot be eliminated. The soft-switching or zero-voltage-switching (ZVS) technique used in active-clamp-flyback (ACF) and LLC converters is a modern, elegant approach to recycling energy within the topology and minimizing loss. Reducing loss, and minimizing transition times and “deadtimes” per switching cycle, allows for faster switching frequency, and in turn reduces the size and cost of magnetic materials.

For power switching, GaN is a new “wideband gap” semiconductor material with 100× faster switching and 20× improved “RxQG” performance than silicon (Si). Early implementations such as depletion mode (dMode), cascoding, and discrete approaches were vulnerable to voltage transients (noise) and required precise voltage control to extract GaN’s potential. This led to large, complex circuits that restricted the switching speed of the application.

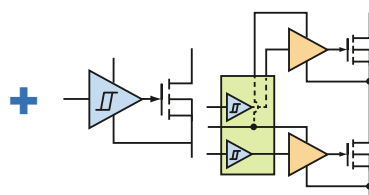
To help solve this problem, Navitas Semiconductor developed the AllGaN process design kit<sup>1</sup>, which uses GaN’s lateral structure to enable the monolithic integration of power FETs,

High-speed, high-efficiency GaN power FETs



- 20X faster than silicon
- 5X faster than cascoded GaN
- Proprietary design
- 15+ pending or issued patents

iDrive integrated GaN gate drivers



- 3X faster than any other gate driver
- Proprietary design
- 10+ pending issued patents

AllGaN Power IC



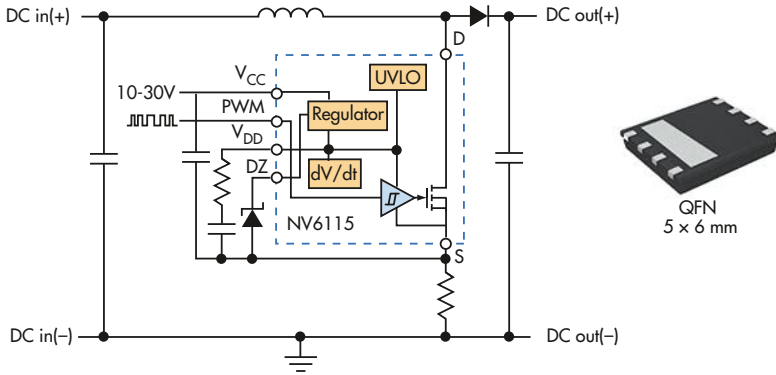
1. Leveraging the AllGaN 650-V lateral technology, a 650-V FET, logic, and driver were monolithically integrated into one IC.

drivers, and logic into a single IC (Fig. 1). Integration is key to minimize delays and eliminate parasitic inductances that restricted the switching speed of Si and earlier discrete GaN circuits. With propagation delays down to 5 ns, and  $dV/dt$  up to 200 V/ns, traditional 65- to 100-kHz converter designs can be accelerated to 1 MHz and beyond.

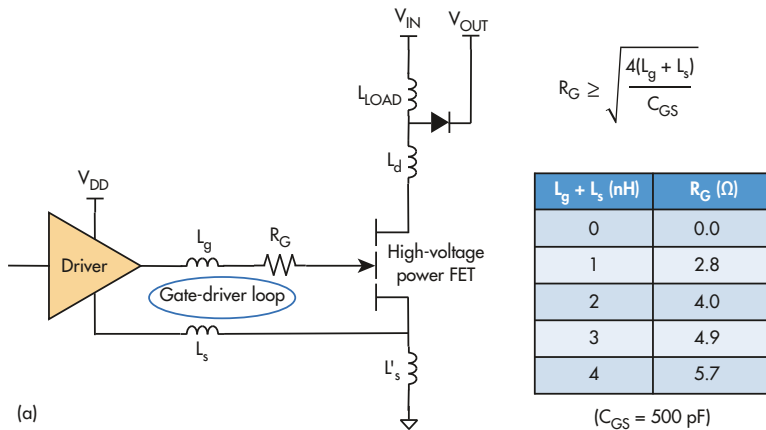
## ADDING FLEXIBILITY

Discrete gate-drive circuits are complex, with high component count and a long design cycle. The digital input of GaN Power ICs (Fig. 2) creates flexibility in design, with options for the power switches to be placed on the main board or on a daughtercard, close to or far from the control IC. Precise internal voltage regulation and no parasitic path to the GaN FET gate ultimately leads to a simple, minimal-component-count, rugged solution. In addition, features like programmable  $dV/dt$  and UVLO help maximize flexibility.

Only by integrating the gate drive onto the same die as the FET (eliminating gate resistance and impedance) is it possible to achieve stability and high efficiency.



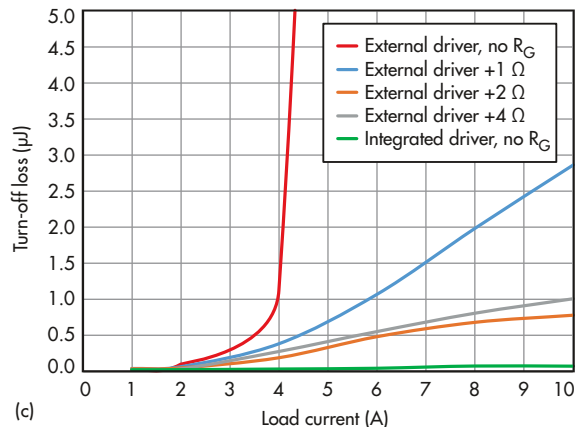
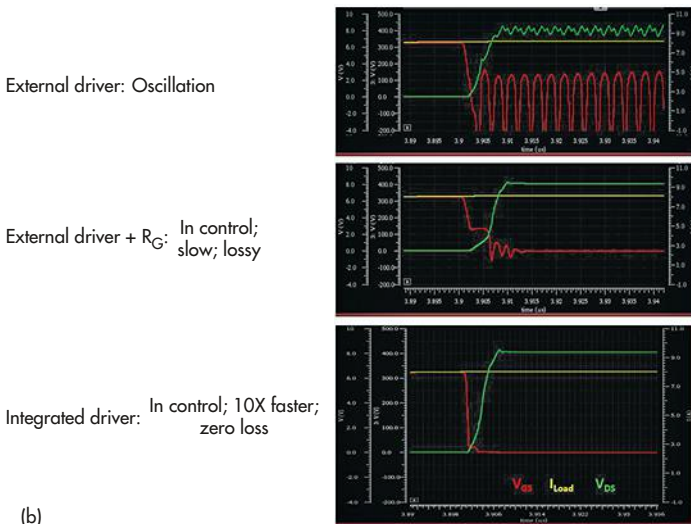
2. Shown is a simplified schematic and packaging for the GaN Power IC.



To better understand the integrated gate drive, let's study<sup>2</sup> the effects of a simple gate-drive “damping” resistor ( $R_G$ ), typically used with traditional driver ICs to control the voltage (reduce oscillation) and protect the vulnerable discrete FET gate. In the progression of Figs. 3a to c, we see that with external drivers, just 1 to 2 nH of gate loop inductance can cause unintended turn-on. While gate resistors reduce the voltage spikes, they create additional losses. Thus, the system becomes limited in terms of switching frequency. Only by integrating the gate drive onto the same die as the FET (eliminating gate resistance and impedance) is it possible to achieve stability and high efficiency.

Moving from the study of a single switch to a half-bridge implementation, we can see that the switching waveforms—even at a frequency of 1 MHz—exhibit a true “textbook” appearance, with very clean rising and falling edges and no ringing (Fig. 4). Integration eliminates gate overshoot and undershoot, while zero inductance on-chip ensures no turn-off loss. This lack of ringing or overshoot makes it easier to tightly control deadtime in half-bridge circuits. Notice that the voltage transitions are smooth

3. This comparison of a discrete and integrated gate drive illustrates the parasitic inductance and (damping) resistance between driver and FET gate (a), stability performance versus a gate resistor (b), and efficiency performance versus a gate resistor (c).





# PICK YOUR COLOR

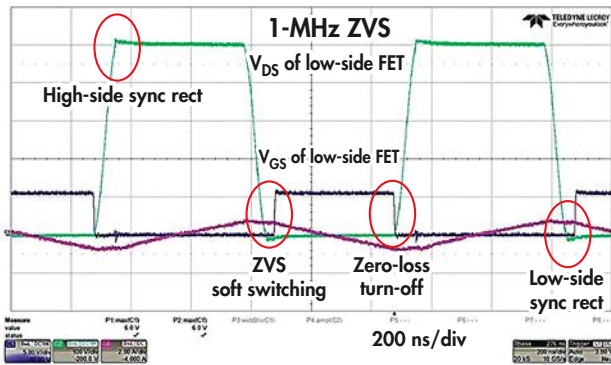
**MPD**  
MEMORY PROTECTION DEVICES

MPD IS A GLOBAL MANUFACTURER OF BATTERY HOLDERS AND OTHER ELECTRONIC COMPONENTS. WE BELIEVE THAT OUR COMPONENTS SHOULD FIT EASILY INTO YOUR DESIGNS, WHICH IS WHY WE ARE ALWAYS CREATING INNOVATIVE NEW PRODUCTS.

[BATTERYHOLDERS.COM](http://BATTERYHOLDERS.COM)

**R**ecent efficiency certification requirements, such as the U.S. Department of Energy’s “Level VI” and the European Union’s “Certificate of Conformance” (CoC), plus connector/interfacing standards like USB-PD, have introduced higher performance demands from, and pushed more components into, power-supply designs.

“S”-curves. This means that the electromagnetic signature is very “quiet” and EMI filter design is simplified as well.

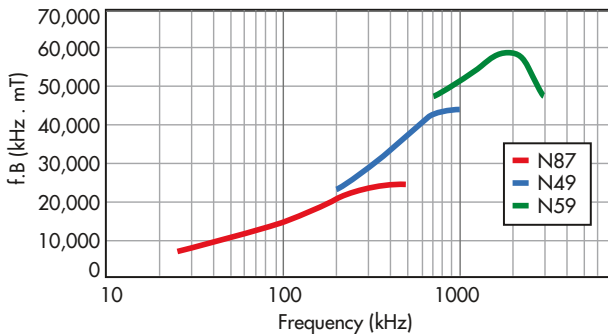


4. In a 1-MHz half-bridge implementation, the switching waveforms feature clean rising and falling edges and no ringing.

**A SMALLER OPTION**

Unlike most Si and earlier discrete GaN devices, GaN Power ICs come in low-profile, surface-mount 5- × 6-mm QFN packages, eliminating the discrete drive and protection circuits, and shrinking printed-circuit-board (PCB) area.

As mentioned earlier, high-speed (i.e., high switching frequency) power conversion creates an opportunity to shrink magnetic circuit elements (transformers, inductors). Here,



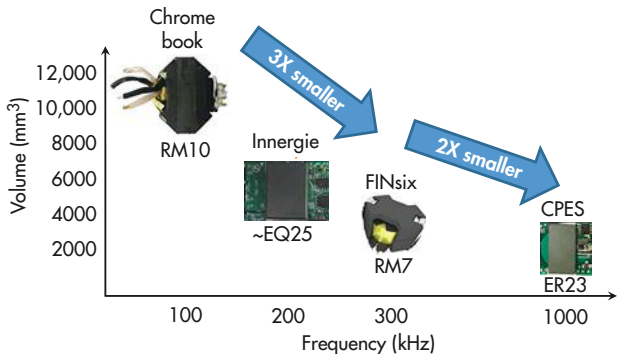
5. Power factors of different ferrite materials vs. switching frequency: The N59 by TDK ferrite material offers a power factor of around 60,000 at 2 MHz. (Courtesy of TDK)

designs are selected based on switching frequency, topology (current waveforms), and voltage step-down ratio (turns). Many options are available for 50- to 500-kHz operation. In addition, recent introductions<sup>3</sup> by TDK (N59) and Hitachi Metals (ML91S), which are optimized for 1 to 2 MHz, open up new opportunities for circuit designers to choose new high-frequency ferrite materials (Fig. 5).

As shown in Fig. 6, size is reduced and transformer format changes (from bobbin-based to planar) with increases in frequency. The change to soft-switching topology and use of high-performance GaN also increases efficiency, thus helping to minimize heatsinking as well.

This higher power density (W/in.<sup>3</sup>) translates into smaller power converters or more power in the same size case. For consumers, this means a single, small, light travel adapter that can more quickly charge a laptop, a tablet, a smartphone, and low-power wearable devices.

Recent efficiency certification requirements<sup>4</sup>, such as the U.S. Department of Energy’s “Level VI” and the European Union’s “Certificate of Conformance” (CoC), plus connector/interfacing standards like USB-PD<sup>5</sup>, have introduced higher performance demands from, and pushed more components into, power-supply designs. Without an improvement in power-conversion density enabled by higher switching frequency, adapters will only increase in size and cost. In non-mobile applications like flatscreen TVs, smaller size can be translated



6. Increasing converter switching frequency allows for new, smaller transformer form factors.



# Powerful, Versatile and Affordable...

## 100 kHz Dynamic Signal Analyzer



**SR785 .... \$13,950 (U.S. list)**

- **DC to 100 kHz frequency range**
- **100 kHz real-time bandwidth**
- **Dynamic range**
  - 90 dB (FFT)**
  - 145 dB (swept-sine)**
- **Low-distortion (-80 dBc) source**
- **Up to 32 Mbyte memory**
- **GPIB and RS-232 interfaces**

**FFT analyzers starting at \$4950**

The SR785 Dynamic Signal Analyzer offers state-of-art performance at a fraction of the cost of competitive analyzers. Standard features include swept-sine mode, order tracking, octave analysis, curve fit/synthesis, and arbitrary waveform source.

When compared to the Agilent 35670A, the SR785 comes out on top. It offers twice the frequency range (2 ch.) and 10 times the real-time bandwidth at less than half the price of the 35670A.

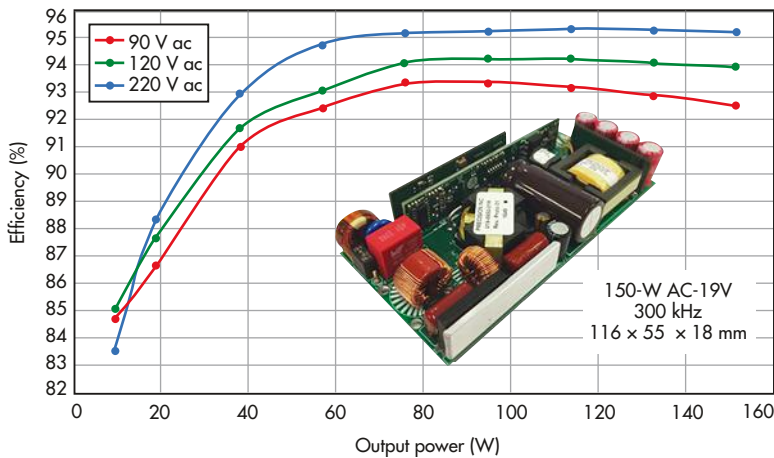
The SR785 is ideal for filter design, control systems analysis, noise measurement, audio or acoustical test, and mechanical systems analysis.

Take a close look at the SR785.



**Stanford Research Systems**

1290-D Reamwood Ave., Sunnyvale, CA 94089 • e-mail: [info@thinkSRS.com](mailto:info@thinkSRS.com)  
Phone (408) 744-9040 • Fax (408) 744-9049 • [www.thinkSRS.com](http://www.thinkSRS.com)



7. A 150-W, 19-V ac-dc converter, using commercial control ICs and a GaN Power IC powertrain at 300 kHz, enabled small size and higher efficiencies across line and load conditions.

as low-profile power conversion and the elimination of the thick power-supply “bulge.”

In one simple example, an AC-19V adapter was built from commercially available control ICs, and a GaN Power IC high-voltage powertrain (Fig. 7). The topology is standard critical conduction- (or boundary-) mode boost PFC (using NCP1615), followed by a ZVS LLC circuit (NCP1399AX1) and synchronous rectification (NCP43080). Note that the GaN Power ICs are mounted on a daughtercard, remote from the control ICs, indicating a robust digital connection between control IC pulse-width-modulation (PWM) output and GaN Power IC input.

Typical switching frequencies for this type of application are 65 to 100 kHz, with power densities around 9 W/in.<sup>3</sup>. In this example, the frequency was increased to ~300 kHz (the maximum allowed by the available control ICs). With the GaN Power ICs, the “cased” power density increased to over 20 W/in.<sup>3</sup> with commensurate efficiency increases to over 95% at 220 V<sub>AC</sub> and over 92% at 90 V<sub>AC</sub>, full load.


**KEEPING AN EYE ON COST**

As low-voltage Si CMOS manufacturing with finer geometries has moved to 200-mm- or even 300-mm-diameter wafers, 650-V GaN Power ICs are manufactured on legacy, high-capacity 150-mm equipment. The ability to grow a very thin GaN epitaxial layer onto an inactive Si substrate (GaN-on-Si) has led to more cost-effective, high-volume manufacturing. And when coupled with standard QFN packaging, the GaN Power ICs have become cost-competitive at a component level. When additional functions and features—such as driver, logic, and protection — are considered, in addition to savings realized with magnetics, PCB, case, heatsinks, etc. due to higher frequency and higher efficiency, it’s possible to reduce overall system bill-of-material (BOM) costs.

To summarize, GaN Power ICs offer one way to achieve predictable, high-performance, commercially viable power converters. Their integrated building blocks enable fast-switching topologies with simple “digital-in, power-out” performance.

As frequencies increase, the transition from traditional wound bobbins to planar magnetics—where the transformer windings are the embedded printed-circuit-board tracks—represents another cost-saving area. Typically, 40% of the cost of a bobbin-based component is in manual labor. With planar magnetics, cores are simply assembled by the power-supply manufacturing company. At 150 W, the cost of the transformer can drop by more than 50% from a 100-kHz design to one at 500 kHz.

For the system designer, integration means simpler, faster component selection and layout, more predictable prototypes with easier qualification, and shorter times to market. For the purchasing managers and quality engineers, integration means fewer components to select, qualify, and procure, thus reducing time and cost associated with those tasks.

To summarize, GaN Power ICs offer one way to achieve predictable, high-performance, commercially viable power converters. Their integrated building blocks enable fast-switching topologies with simple “digital-in, power-out” performance. When switching frequencies increase from 100 kHz to 300 kHz on up to 1 MHz, power converters simultaneously achieve size reductions and increased efficiencies. 

**REFERENCES**

1. “Breaking Speed Limits with GaN Power ICs,” D. Kinzer, APEC 2016 keynote, <http://www.navitassemi.com/white-papers-articles/>
2. “650V AllGaN™ Power IC for Power Supply Applications,” M. Giandalia, WIPDA 2016, <http://www.navitassemi.com/white-papers-articles/>
3. TDK/EPCOS N59/PC200: <https://en.tdk.eu/tdk-en/374108/tech-library/articles/products---technologies/products---technologies/low-losses-at-high-frequencies/1206400>
- Hitachi Metals ML91S: <http://www.hitachi-metals.co.jp/e/press/news/2016/n0404.html>
4. “Efficiency standards for external power supplies,” CUI, <http://www.cui.com/efficiency-standards>
5. “USB Power Delivery,” Universal Serial Bus, <http://www.usb.org/developers/powerdelivery/>



INDUSTRIAL DESIGN &  
ENGINEERING SHOW

Brought to you by

machine  
design

electronic  
design

May 8-10, 2017 | Huntington Convention Center of Cleveland | Cleveland, OH



# REGISTER TODAY!

The Industrial Design & Engineering Show unites the engineering community, from design engineers and plant managers to the top companies and engineering firms, to learn and exchange application methods for the latest emerging technologies. The main purpose is to help engineers better understand the new emerging technologies such as the Internet of Things, artificial intelligence, or 3D printing and how to translate those fields into real world applications. Join us in Cleveland this May!

For more information, please visit [mfgtechshow.com](http://mfgtechshow.com).

**SAVE \$100 ON EARLY BIRD REGISTRATION!**

For additional questions, please contact [tara.tonsetic@penton.com](mailto:tara.tonsetic@penton.com)

Co-located with





## What's the Difference?

ROBIN SCHNEIDER, Ph.D. | Technical Marketing Director

# Lead-Acid Battery Applications Drive the Li-ion Market

Although important, neither consumer electronics nor electric vehicles are the main forces behind the growth in new battery technologies—instead it's coming from “everything else.”

**T**he consumer market for lithium-ion (Li-ion) batteries is huge—about \$10 billion worth of battery packs—but it's also relatively flat with only a modest 2% growth rate. Of course, there's a news-grabbing growth market for electric vehicle batteries, with a forecasted compound annual growth rate (CAGR) of 10%, reaching \$10 billion in 2025. Surprisingly, though, the biggest growth area for adoption of new batteries is “everything else,” from forklifts to ventilators. This battery market, which often falls into the “medium format” category, is maintaining a robust 11% CAGR and is also expected to reach \$10 billion by 2025.

These “other” applications for Li-ion batteries generally have one thing in common—they're devices that were typically powered by sealed lead acid (SLA). SLA batteries cornered the portable power market for the last nearly 200 years, but that's finally changing thanks to Li-ion chemistry formulations with more diverse capabilities and more sophisticated electronics available. Because Li-ion batteries are directly replacing SLA in many cases, it's worth comparing and contrasting Li-ion and SLA batteries, highlighting the commercial and technical applications for Li-ion in traditional lead-acid products.

### HISTORY AND APPLICATION

Lead acid was the first rechargeable battery developed for commercial use in the 1850s. Although lead acid has been around for more than 150 years, it continues to be widely used. Not only is it still found in many of the same applications that it originally enabled, new uses for this old technol-

ogy are being discovered to this day. Some common applications include backup power or uninterruptible power supply (UPS), and motive applications such as golf carts and forklifts. The lead-acid market is still growing at 4% for niche industries, and projects to be a \$1.6B market by 2020 for these applications alone.

The first, and perhaps only, significant innovation to lead-acid technology came in the 1970s, namely sealed lead acid (or maintenance-free lead acid). It includes valves to control venting of gases during charge or rapid discharge. Also, instead of submerging the metal plates in liquid electrolyte, a moistened separator makes it possible to use the battery in any orientation without leakage.

SLA batteries are often categorized by type or application. Two types of SLA technology are common today: gel, also known as valve-regulated lead acid (VRLA), and absorbent glass mat (AGM). AGM batteries are used for small UPS, emergency lighting, and wheelchairs, while VRLA targets larger-format applications such as power backup for cellular repeater towers, internet hubs, and forklifts. Lead-acid batteries can also be categorized by use: automotive (starter or SLI—starting, lighting, ignition); motive power (traction or deep cycle); and stationary (UPS). The major drawback of SLA in all of these applications is cycle life—if the SLA batteries repeatedly drain, they're heavily damaged.

Remarkably, the market dominance of lead-acid batteries remained relatively unchallenged for hundreds of years until the introduction of Li-ion batteries in the 1980s. A Li-ion battery is a rechargeable cell in which lithium ions move



1. Shown are examples of Li-ion cells incorporated into battery packs with electronics and either hard-plastic enclosures or shrink-wrapping.

from the negative electrode to the positive electrode during discharge and back when charging. The nomenclature can be confusing, though. Li-ion batteries use an intercalated lithium compound, but don't contain metallic lithium, which is used in lithium-based one-time-use cells.

The Li-ion battery was first invented in the 1970s. In the 1980s, a commercial version of the Li-ion battery, with a cobalt-oxide-based cathode, was introduced to the market. This battery featured a significantly better capacity by both weight and volume than nickel-based systems, which had primarily found use in hobby applications and limited adoption in early consumer portable electronics.

The new Li-ion batteries enabled enormous growth in cell-phone and laptop markets. Initial safety concerns were abated by the introduction of safer variants that incorporated manganese and nickel-based additives into the cobalt-oxide cathode material, in addition to innovations in cell construction.

The first Li-ion cells introduced to the market were in hard aluminum or steel cans, and generally only a handful of cylindrical and prismatic (brick shaped) form factors were available. However, as more applications adopted Li-ion technology, more variations on the cells emerged in terms of physical form, chemical performance, and price point.

For example, less expensive versions of the older technology lead to the adoption of laptops and cell phones all over the world. Modern, thin Li-polymer cells enabled smartphones, tablets, and wearable electronics. Now high- and medium-rate Li-ion batteries are used in power tools and e-bikes, respectively. Such variation foreshadows the replacement of SLA in more and more applications looking to improve weight and cycle life.

### CHEMISTRY FEATURES

The fundamental working chemistry of the cells lends SLA and Li-ion batteries to certain features and different degrees of functionality. What follows are some of the benefits of SLA that have made it the solution of choice for many years and the deficiencies that now threaten it for replacement, as well as the attributes and challenges surrounding Li-ion batteries:

### SLA

- SLA is simple, dependable, robust, and inexpensive, and can be used in a wide range of temperature environments.
- The batteries must be stored full state-of-charge (SOC), and they don't lend themselves to fast charging.
- The flip side to the charge constraints is that SLA batteries can use simple float or trickle chargers.
- SLA batteries are very heavy; their gravimetric energy density is very low.
- Cycle life is usually 200 to 300 cycles, but even a "deep cycle" SLA is damaged by repeated full discharges, causing cycle life to be as low as 50 cycles.
- The sloped discharge curve enables SOC measurement with simple voltage monitoring.

### Li-ion

- Conventional Li-ion cells are designed to offer the highest energy density by size and weight.
- Cycle life is generally 300 to 500 cycles, but can be in the thousands for Li-iron phosphate cells.
- The operating temperature is relatively narrow.
- A variety of cell sizes, shapes, and current capabilities are available.
- Maintenance cycling isn't required and self-discharge is low.
- They require safety circuitry and complex charging algorithms.
- SOC measurement is complex because of the flat voltage discharge curve.

### ELECTRONICS

It's important to distinguish between a battery cell and a battery pack. The cell is the fundamental building block of a pack; the pack includes the electronics, connectors, and enclosure. Fig. 1 shows some examples of battery cells and packs. At a minimum, a Li-ion battery pack needs to have safety circuitry to protect and manage the cells, and the charger and fuel gauge must be more complex than those used with SLA technology.

In addition to these issues, the electronics employed in a traditional SLA application will often have special requirements. Generally, these battery packs are “medium format,” i.e., larger than one- or two-cell packs common in consumer electronics and smaller than the enormous batteries used in electric vehicles. In addition, SLA applications are often motive, such as wheelchairs and forklifts, and the motor may introduce system noise and require electronics suited to high power.

When employing Li-ion in an SLA application, some of the differences in the electronics include:

- **Charging:** Charging a lead-acid battery is simple when observing the correct voltage limits. Li-ion must generally use a more complex algorithm, with the exception of iron-phosphate-based packs (discussed later). The standard method for charging Li-ion batteries is the constant current/constant voltage (CC/CV) method. It incorporates a two-step process of CC followed by a CV charge phase. In the first stage of the charging process, a constant current is applied. This stage continues until the battery-pack voltage approaches the preset threshold at the charger contacts. Once the charging voltage approaches the preset level, current begins to taper exponentially until a cutoff threshold is achieved.

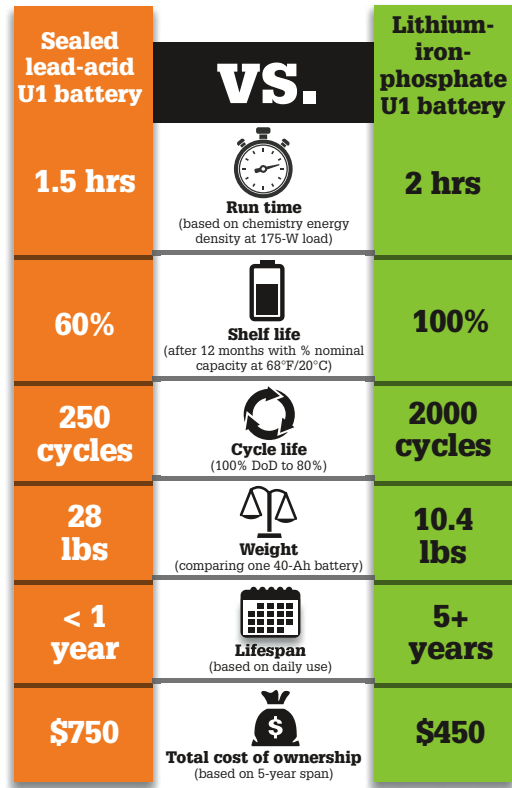
An alternative variation is virtual voltage termination (VVT). By eliminating the effect of resistive losses in the battery pack, the VVT charging algorithm charges the battery-cell stack rather than the outside battery terminals. The charging algorithm therefore doesn’t deviate from the industry-accepted method for Li-ion battery packs. With VVT, the CC stage extends for most of the charging period, until the microprocessor senses nominal cell voltage and initiates the transition event.

- **Fuel gauging and communication:** As mentioned earlier, SLA batteries are generally monitored with a simple voltage measurement. Li-ion batteries require a coulomb-counting method, which calls for learn cycles or a variation of cycles, or a combination of coulomb counting and impedance lookup tables to avoid the learn cycles.

I<sup>2</sup>C is the most common and cost-effective communications protocol used in Li-ion batteries, but it has limitations with respect to noise immunity, signal integrity over distance, and overall bandwidth. SMBus (System Management Bus), a derivative of I<sup>2</sup>C, is very common in smaller batteries, but currently lacks any particularly effective support for high-power packs or larger packs. CAN is terrific for high-noise environments or where long runs are needed, such as in many SLA applications, but it comes at a cost.

**DIRECT REPLACEMENTS**

Surprisingly, there are few standard SLA formats. One of them is the U1, a common standard form factor used in medical-equipment backup applications. Li-iron-phosphate chemistry has enabled the development of direct drop-in replacements for these batteries. Iron phosphate features remarkable cycle



2. U1 replacement batteries have features that contribute to a more efficient model, resulting in significant cost savings over the life of a medical device.

life, high-current delivery capability, increased safety, and low impedance. The voltage of Li-iron-phosphate batteries also matches well with SLA at 12- and 24-V increments, and allow for use with conventional SLA chargers. Packs incorporate smart features such as state-of-charge and cycle-count communication at about one third the weight.

Li-iron-phosphate batteries maintain 100% capacity in storage, unlike SLA batteries that experience permanent capacity loss within a few months of storage. Fig. 2 compares the two products and the types of gains achieved when switching from SLA to Li-ion.

**CONCLUSION**

Few other batteries can deliver bulk power as cheaply as lead acid, which makes the battery cost-effective for larger applications. Li-ion technology is coming down in price point and new varieties are available in both chemistry and electronics that make Li-ion a potential replacement for SLA, with significant upside in cycle life and weight. Applications ripe to take advantage of this technology include material-handling equipment, battery-backup units, lawn and garden equipment, industrial cleaners, aerial scissor lifts, industrial drones, golf carts, and other motive applications, all of which are fueling Li-ion’s growth in niche, medium-format markets.

## Added ADC Improves Analog Square-Root Extraction Accuracy

By YAKOV VELIKSON | yvelikson@yahoo.com

**KNOWN DEVICES FOR** taking the square root contain an operational amplifier and a multiplier connected in a feedback loop. The accuracy of these devices depends on the method of building the multiplier, with the most accurate using logarithm and anti-logarithm functions. However, even these are not accurate to better than  $\pm 0.1\%$  without trimming or calibration. The circuit proposed here removes this limitation associated with the analog multiplier by using analog-to-digital conversions to increase the accuracy of the square-root derivation.

The device is based on the ratio:

$$K^2(1 - N)^2 = X$$

where  $K^2$  is a constant and  $X$  is proportional to  $V_{IN}^2$ , resulting in:

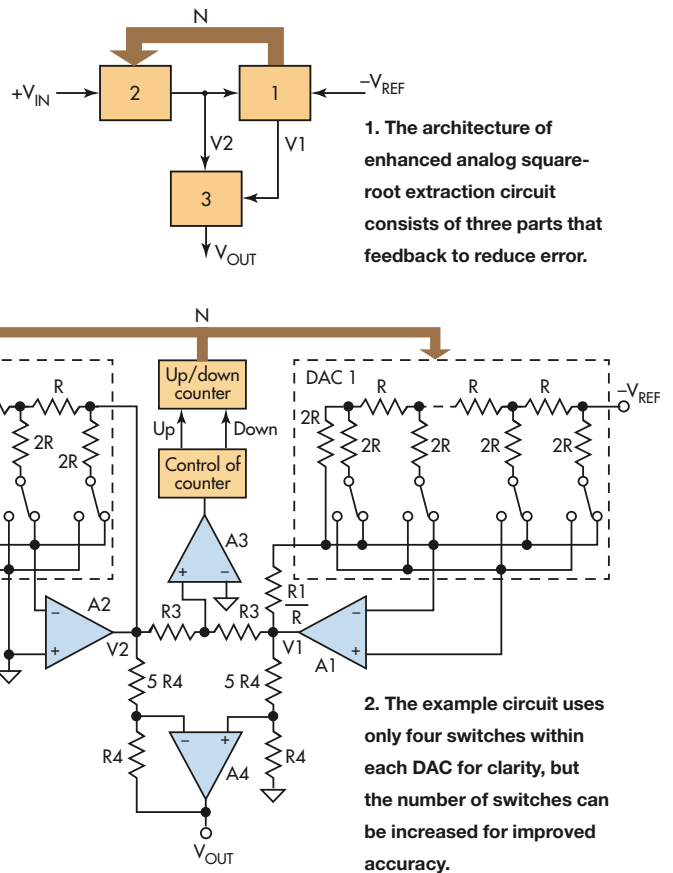
$$K(1 - N) = \sqrt{X}$$

and

$$K(1 - N) = X/K(1 - N)$$

These ratios are realized in this device by creating two voltages in approximate balance:  $V_1$ , which is proportional to  $K(1 - N)$ , and  $V_2$ , which is proportional to  $X/K(1 - N)$ .  $N$  is constrained as  $0 \leq N < 1$ .

The approach (Fig. 1) consists of three functional parts, where two chains create voltages for subsequent comparison. *Part 1* consists of reference voltage  $V_{REF}$ , an analog-to-digital converter (ADC) with digital-to-analog converter (DAC), an operational amplifier (op amp), a comparator, and an up/down counter with a control circuit. *Part 2* contains an op amp with a DAC connected in feedback, creating the signal of the ADC. *Part 3* is a summing amplifier that sums the outputs of Parts 1 and 2 and scales the output voltage proportional to the square root of the input voltage.



In the example circuit (Fig. 2), the analog part of the device contains amplifiers A1, A2, and A4; the digital-to-analog part consists of DAC1 and DAC2; and the digital part is the up/down counter. This example uses only four switches within each DAC, but the number of switches can be increased to enhance the accuracy.

In Part 1, resistor R1 is connected in feedback to DAC1, and is proportional to  $R - 2R$  of DAC1:  $R_1 = n_1 R$ . The output voltage of A1 is:

$$V_1 = n_1 V_{REF}(1 - N)$$

# INDUSTRIAL & MEDICAL Modem Modules

Radicom Research has been building standard and custom OEM modem modules for the past 20 years. We offer fast turn-around times at a very competitive price.

## WiFi Modules



WiFi 802.11b/g/n  
USB & Serial interfaces  
-40°C to +85°C operating temp.  
Available AP, Router & Device

## BLUETOOTH® Modules



Classic & V4.0 BLE  
Serial TTL interface  
SPP, HID, HCI, A2DP, USB, 12S  
-40°C to +85°C operating temp.

## PSTN Modems



USB, Serial, RS232, ISA, PC104  
Leased-line & Dial-up  
Medial, Contact ID applications  
-40°C to +85°C operating temp.

## Ethernet Adapters



Serial-to-Ethernet  
USB-to-Ethernet  
Available IEC60601-1 certified model

**Radicom**  
Affordable Modem Technology

www.radi.com  
modems@radi.com  
408-383-9006 x112

## Ideas for Design

In Part 2, R2 is also proportional to R-2R of DAC2:  $R2 = n_2 R$ . The output voltage of A2 is:


$$V_2 = -[V_{IN}/n_2(1 - N)]$$

The value of  $(1 - N)$  is defined by setting all switches in both DAC1 and DAC2 to their initial position and the last resistor in the network as R-2R. The rise of N determines the decrease of voltage gain  $V_1$  and the increase of voltage  $V_2$ . A decrease in N results in the opposite change. Voltages  $V_1$  and  $V_2$  are compared by comparator A3. The output of A3 is binary with two levels for operating the counter control, which consists of a pulse source and switches for up/down pulse count.

With  $V_1$  and  $V_2$  in approximate balance, the errors of these voltages are in the range of the least significant bit (LSB) and have opposite polarity, so combining them can achieve a partial correction of the end result. This is done by connecting  $V_1$  and  $V_2$  to amplifier A4 by two resistor divisors  $R4/(2n_3 \times R4)$ , where  $V_1 = V_2 = n_3 \sqrt{V_{IN}}$ .

In this example, the scale factors have been chosen to keep calculations simple,

based on a standard analog range of  $0 < V_{IN} \leq 10 \text{ V}$  for the input voltages and a  $V_{REF} = -10 \text{ V}$ . For the maximum  $V_{IN} = 10 \text{ V}$ , choosing  $n_2 = 1.6 = 4/2.5$  allows the choice of K = 4, yielding  $n_1 = 1.0$  and  $n_3 = 2.5$ .

The accuracy of this circuit is limited only by the number of switches in each DAC, with each additional switch representing the next least significant bit in binary. Note that  $N = z/(z_{MAX} + z_0)$ , where z is the current sum of all bits,  $z_{MAX}$  is the maximum possible sum, and  $z_0$  is the least significant bit. The proposed scheme thus provides a way of increasing the accuracy of square-root derivation beyond that of conventional integrated circuits. 

### REFERENCE

Tietze, Ulrich, Christoph Schenk, & Eberhard Gamm. 2nd ed., Springer 2008.

**YAKOV VELIKSON** retired from Kerfott Guidance & Navigation Corp. He holds a PhD in electrical engineering from St. Petersburg Electrotechnical University and is the author of 45 patents in the areas of analog-to-digital and digital-to-analog processing.

# Set DC-Motor Speed with Light-Controlled Microcontroller Circuit

By FIRAS MOHAMMED ALI AL-RAIE | University of Technology, Baghdad, Iraq

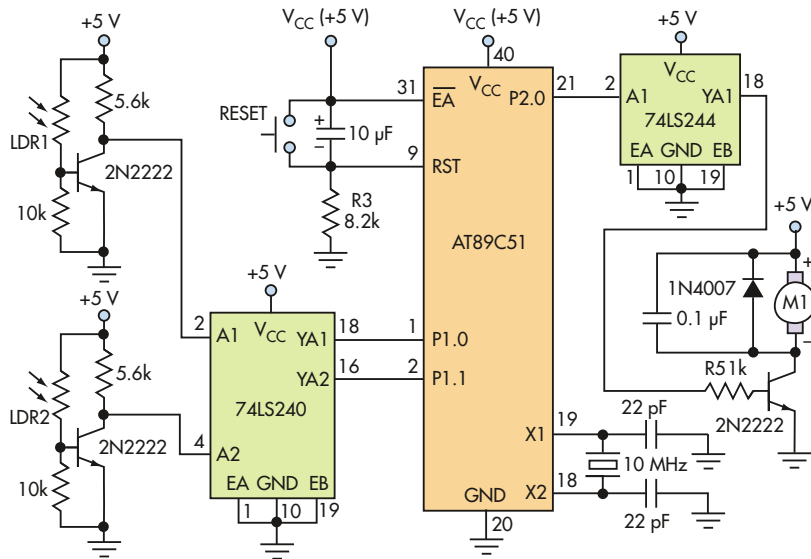
**THIS 8051 MICROCONTROLLER-BASED** control circuit adjusts the speed of a small permanent-magnet dc motor via photosensors (see figure). The circuit can find applications in light-tracking systems for adjusting tracking-motor speed depending on the intensity of the incident light. It can also be modified to control more than one motor at the same time.

The circuit and software varies the speed of the motor in three levels,

depending on two photosensors connected to the microcontroller. The microcontroller input port (Port 1) senses the voltage level of each photosensor circuit, while the program stored in the microcontroller's memory produces the necessary pulse-width-modulation (PWM) signal at its output port (Port 2) to drive the motor circuit.

Motor speed can be adjusted by the light intensity falling into the photoreistors LDR1 and LDR2. These resistors





This dc-motor speed-control circuit uses standard, available components; light impinging on two independent phototransistors establishes the motor's speed.

control the bias points of two transistors connected via an input inverting buffer (74LS240) to Port 1 of the AT89C51. The base and collector resistors of the photosensor circuit were chosen empirically to properly set the transistor in cutoff and saturation regions. The output signal from Port 2 of the microcontroller is delivered to the motor circuit with the aid of a non-inverting buffer (74LS244).

When there's no light incident on either of the LDR photoresistors, its resistance will be large (reaching to approximately 1 M $\Omega$ ) and thereby turning the transistor off. In this case, the collector voltage of this transistor will be high (+5 V). On the other hand, when the light brightness increases on the photoresistor, its resistance will decrease to about 1 k $\Omega$  at full-light illumination, thereby causing the NPN transistor (2N2222) connected with it to switch on. In this case, the collector voltage of the transistor will be low.

The inverting buffer (74LS240) is used to invert the signal levels at the nodes of the transistors' collectors. When either of the two transistors is on, the signal at the input of the respective buffer (A1 or A2) is at logic 0 (grounded), and in this

case, the buffer output (YA1 or YA2) is high. On the other hand, when the transistors are off, the corresponding output of the buffer is low. This buffer is also used to protect Port 1 of the 8051 microcontroller.

The 74LS244 buffer protects Port 2 of the 8051 microcontroller from the motor circuit and provides sufficient current to drive the output transistor. The dc motor is connected to a +5-V dc supply via the driving transistor. And a free-wheeling diode is connected across the dc motor to protect the transistor from any back-induced voltage. The capacitor in the motor circuit removes the EMI and noise produced during motor operation.

When the output signal from pin P2.0 is set HIGH (Logic 1), current passes through the buffer and the base of the driving transistor. This turns on the driving transistor and the dc motor. The signal generated at pin P2.0 is a pulse-width-modulated waveform to control the average voltage provided to the motor, by controlling the switching-on time of the driving transistor. The control program stored in the memory of the 8051 microcontroller will generate this signal.



**100 to 10,000**  
VDC Output DC-DC CONVERTERS

4 Watt to 10 Watt Series  
Surface Mount & Plug In  
Over 250 Standard Models!

Isolated Outputs/  
Proportional V in and V out  
Miniature fully encapsulated modules  
for operation in rugged environment

**Military options available**

Expanded operating temperature  
-55° to +85° C Ambient

Military Standard 883 Selected  
testing available

Will review all Customer Specifications  
for custom design specifications

Over 2,500 standard high and  
low voltage DC-DC converters and  
AC-DC power supplies

Industrial/Cots/Military  
Isolated/Regulated/Proportional/  
Programmable

Also Thousands of Hi reliability,  
Ultra Miniature Transformers  
and Inductors

US Manufactured  
since 1969

See PICO's full line catalog on  
our NEW WEBSITE

[www.picoelectronics.com](http://www.picoelectronics.com)

**800-431-1064**

**PICO** ELECTRONICS, Inc.

143 Sparks Ave., Pelham, New York 10803

Call Toll Free 800-431-1064 • FAX 914-738-8225

E Mail: [info@picoelectronics.com](mailto:info@picoelectronics.com)



The control program (see the listing) was converted into a hex machine-code file using the ASEM-51 assembler, and then burned into the flash memory of the AT89C51 using a commercial universal programmer. The selection of the required speed is achieved by controlling the light falling on LDR1 and LDR2 (see the table).

```

motor - Notepad
File Edit Format View Help
: DC MOTOR SPEED CONTROL
ORG 00H
MOV P1, 0FFH
BEGIN:
MOV A, P1
ANL A, #03
CJNE A, #00, SPEED1
CLR P2.0
SPEED1:
SIMP BEGIN
CJNE A, #01, SPEED2
SETB P2.0
ACALL DELAY
CLR P2.0
ACALL DELAY
ACALL DELAY
ACALL DELAY
SIMP BEGIN
SPEED2:
CJNE A, #02, SPEED3
SETB P2.0
ACALL DELAY
CLR P2.0
ACALL DELAY
ACALL DELAY
ACALL DELAY
SIMP BEGIN
SPEED3:
SETB P2.0
ACALL DELAY
CLR P2.0
ACALL DELAY
ACALL DELAY
ACALL DELAY
SIMP BEGIN
DELAY:
MOV R0, #0FFH
NOP
DJNZ R0, H1
RET
HERE:
SIMP HERE
END
    
```

Port 1 is defined as an input port, while Port 2 is left as an output port. The received signal from Port 1 is masked with the binary number 00000011 using the ANL logic instruction, to check the value received by Port 1 depending on the states of the photosensors. This value

DC-MOTOR SPEED LEVELS			
LDR2	LDR1	Duty cycle	Motor speed
OFF	OFF	0%	Standstill
OFF	ON	25%	Minimum
ON	OFF	50%	Medium
ON	ON	100%	Maximum

is compared with 00, 01, 02, and 03, respectively, to send the appropriate PWM signal into the motor circuit. A delay sub-routine is included to produce the necessary delay times for the required PWM signals.

**FIRAS MOHAMMED ALI AL-RAIE** holds BSc and MSc degrees in electrical engineering from the University of Technology, Baghdad, Iraq, where he is a Teaching Staff Member. He has done extensive design work related to communication systems and RF amplifiers, and can be reached at [firas@ieee.org](mailto:firas@ieee.org)

## LED-String Driver Operates from Single Cell

By LUCA BRUNO | Lissone, Italy

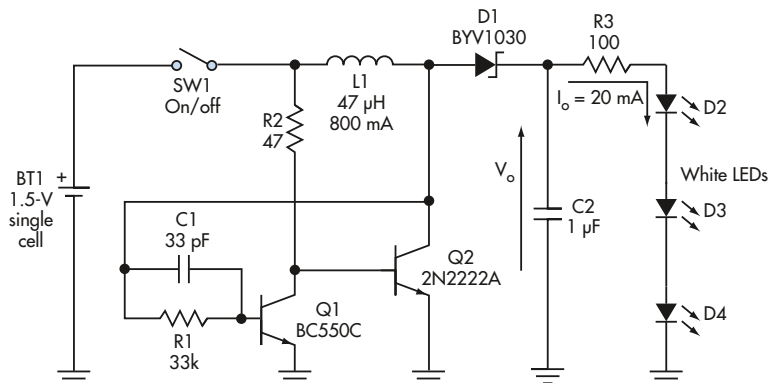
**THIS DESIGN DESCRIBES** how to light a string of LEDs of any color from a 1.5-V cell using just a few inexpensive components. The circuit (see figure) forms a self-oscillating, unregulated step-up converter that can deliver an average output power of about 230 mW to a load when the nominal input voltage is 1.5 V, with power-conversion efficiency of approximately 65%. The driver has been tested with a string of three standard white LEDs (see table).

The circuit, though, is also able to power more LEDs connected in series at lower current, within the limit of the available output power. For example, a red LED has a typical forward voltage of 1.9 V at 10 mA, so you can light up to 11 red LEDs at about 10 mA. Applications include a warning light or a small flashlight.

When power is applied in startup, transistor Q2 goes into saturation and the collector current begins to ramp up in inductor L1 until Q2's base current can no longer hold the transistor in saturation. Since that base current is constant for a given battery voltage and inductance value, the peak value of the inductor current depends on current gain hFE2 of Q2 and the inductor's stored energy  $E_{L1}$ , where:

$$E_{L1} = \frac{1}{2} (L1) \times I_{PK}^2 = \frac{1}{2} (L1) \times (h_{FE2} \times I_{B2})^2$$

Transistors Q1 and Q2 are coupled through a positive feedback loop, so when Q2 comes out of saturation, Q1 turns on quickly while Q2 turns off. The voltage across L1 then reverses polarity and it discharges its energy into C2. At this point, Q2 again goes into saturation while Q1 turns off, which starts a new charging cycle.



With a few standard discrete components, this LED driver can source current to a series string of LEDs. It allows for adjustment of operating parameters by changing component values.

## High Efficiency, 15V Rail-to-Rail Output Synchronous Step-Down Regulator Can Source or Sink 5A

Design Note 560

Timothy Kozono

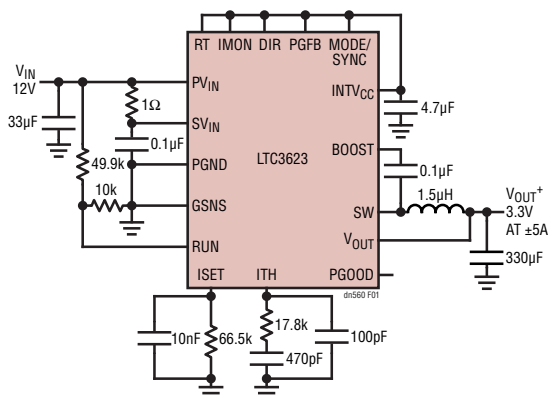
### Introduction

The **LTC®3623** is a high efficiency, monolithic synchronous step-down regulator capable of sourcing or sinking up to 5A of continuous output current from an input voltage range of 4V to 15V. Its compact 3mm × 5mm QFN package incorporates an abundance of features including a low EMI Silent Switcher® architecture, output voltage cable drop compensation and single resistor output voltage programming. The constant frequency/controlled on-time architecture responds quickly to line and load transients even in low duty cycle, high frequency applications. The device offers a 400kHz to 4MHz operating frequency range with multiple optional protection and monitoring features, enabling compact, robust solutions.  $V_{IN}$  regulation, discontinuous/continuous mode and a supply current less than 1 $\mu$ A during shutdown make this regulator suitable for a wide range of power applications.

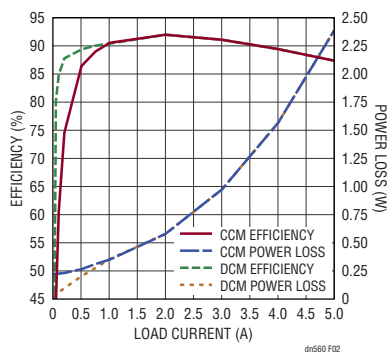
A single resistor is used to set the internal reference voltage for the part. The adjustable internal reference voltage sets the output voltage and allows the output voltage to operate rail-to-rail, from 0V to  $V_{IN}$ . The reference voltage can be driven directly as an audio driver or configured to operate as a TEC driver. Capable of sourcing or sinking 5A of output current, the regulator moves the output voltage quickly in either direction. The output current monitor signal can be used to increase the reference voltage to compensate for output voltage drop caused by cable resistance.

### 3.3V Output, 1MHz Buck Regulator

Figure 1 shows the complete schematic for a high efficiency 12V input to 3.3V output application. The compact package contains a low 30m $\Omega$   $R_{DS(ON)}$  synchronous bottom MOSFET switch and a 60m $\Omega$   $R_{DS(ON)}$  synchronous top MOSFET switch for high efficiency and minimal thermal issues. Figure 2 shows the continuous and discontinuous conduction mode



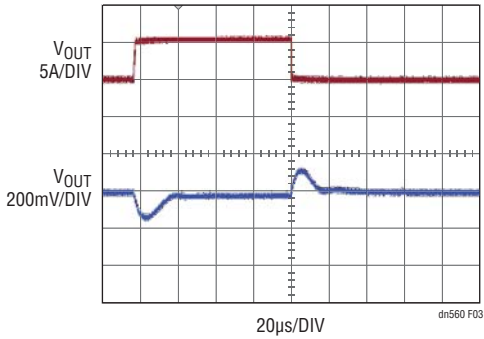
**Figure 1. High Efficiency 12V to 3.3V 1MHz Step-Down Regulator with Programmable Reference**



**Figure 2. Efficiency and Power Loss for the Application in Figure 1 in CCM and DCM Mode**

efficiency and power loss. Discontinuous conduction mode significantly improves light load efficiency while adding a slight increase in output voltage ripple. Figure 3 shows the load-step response with only 330 $\mu$ F of output capacitance.

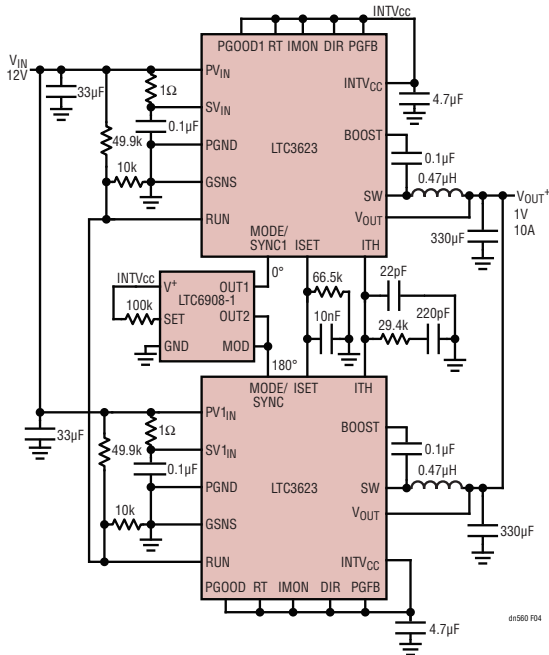
LT, LT, LTC, LTM, Linear Technology, the Linear logo and Silent Switcher are registered trademarks of Linear Technology Corporation. All other trademarks are the property of their respective owners.



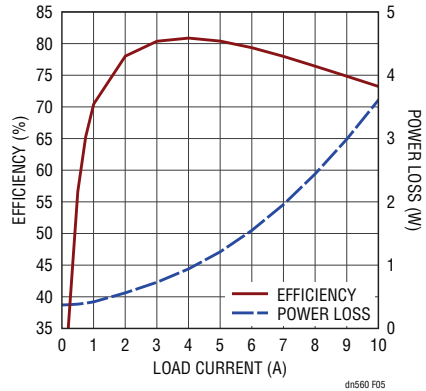
**Figure 3. 0A to 5A Load Step Response of the Figure 1 Schematic**

### Dual-Phase Design Increases Output Current Capability

Figure 4 shows a complete 1MHz 12V input to 1V output dual-phase schematic capable of sourcing or sinking up to 10A. The phases are synchronized by the LTC6908-1 oscillator with 180° interleaving to lower output voltage ripple. Figure 5 shows the efficiency and power loss for the overall system. The low thermal resistance of the LTC3623 package

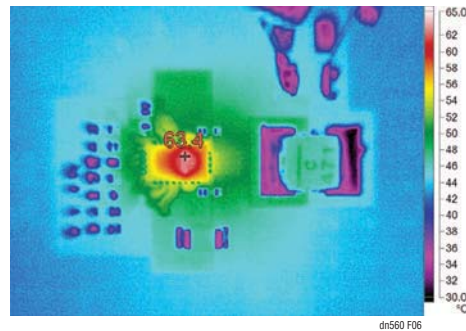


**Figure 4. 12V to 1V at ±10A 2-Phase Buck Converter**



**Figure 5. Efficiency and Power Loss for Application in Figure 4**

uses the PCB to dissipate heat. The thermal image is shown in Figure 6. From Figure 5, we can see that each phase dissipates 1.8W at 10A output current, which raises the chip temperature to 63°C from an ambient temperature of 25°C with no airflow.



**Figure 6. Thermal Image of the Master Phase of the Figure 4 Circuit at 10A with 0LFM Airflow at 25°C Ambient Temperature (38°C Temperature Rise)**

### Conclusion

The LTC3623 step-down regulator enables compact POL solutions that can source or sink 5A without significant thermal mitigation. Power capability is easily expanded by paralleling devices, which has other benefits such as spreading the heat and reducing output ripple. Heat dissipation problems are minimized by the LTC3623's low thermal impedance and high efficiency capability. The LTC3623's extensive set of programmable features satisfies the requirements of a wide range of applications.

Data Sheet Download

[www.linear.com/LTC3623](http://www.linear.com/LTC3623)

For applications help,  
call (408) 432-1900, Ext. 3732

To improve the circuit's efficiency, Q2 should be a fast-switching transistor with current gain as high as possible. You must ensure that inductor doesn't saturate at peak current value, and also that Q2's collector current doesn't exceed its absolute maximum rating. Capacitor C1 is not strictly needed for the operation of the circuit. However, it speeds up the switching time of Q1 and, in turn, the switching time of Q2, thus greatly improving the efficiency of the circuit.

The circuit works with any 1.5-V cell, even with a button cell. A good choice, though, is an alkaline AA-LR6 battery, which can power the circuit for several hours due to its 2700 mA-Hr capacity. To save power and increase battery life, the inductor charge current can be decreased by increasing the value of R2. The brightness of the LEDs diminishes with battery voltage, and the minimum input voltage that can illuminate the LEDs is 0.75 V with an output current of only 0.38 mA. 📧

**LUCA BRUNO** has a master's degree in electronic engineering from Politecnico di Milan, Italy. He has been teaching electronics and telecommunications for 25 years at I.T.I. Pino Henseberger in Monza, and worked at Alfamation Spa in Lissone, a company specializing in ATE. He can be reached at [lucabruno1963@gmail.com](mailto:lucabruno1963@gmail.com).

## IDEAS FOR DESIGN WANTED

Send us your Ideas For Design. We'll pay you \$150 for every Idea For Design that we publish. In addition, this year's top design as selected by our readers will earn an additional \$500, with two runners-up each receiving \$250. You can submit your Ideas For Design via EMAIL at: [roger.engelke@penton.com](mailto:roger.engelke@penton.com)

OR BY POSTAL MAIL to: **Ideas For Design, Electronic Design, 1166 Avenue of the Americas, 10th Floor, New York, NY 10036**

Go to [www.electronicdesign.com](http://www.electronicdesign.com) for our submission guidelines.

## LED DRIVER TEST MEASUREMENTS

V <sub>BAT</sub>	V <sub>OUT</sub>	I <sub>OUT</sub>	I <sub>L1pk</sub>	Q <sub>2</sub> collector voltage		V <sub>OUT_ripple_pp</sub>
				f <sub>OSC</sub>	Duty cycle	
1.5 V	11.3 V	20.5 mA	450 mA	48 kHz	9%	400 mV
1 V	9.75 V	8.9 mA	250 mA	66 kHz	8%	100 mV

## Professional PCB Fabrication Service for Telecommunication, Automation & Test and Measurement Applications

PCBCart has been serving worldwide companies of all sizes with PCB prototype and mass production services for over 10 years. We fabricate 23,000+ different PCB designs each year and we're committed to quality and performance on every circuit board we manufactured.



### Our Advantages:

- Easiest online quoting & ordering system
- Best overall PCB quality, customer services, competitive pricing
- Flexible PCB Assembly and Components Sourcing services available
- Advanced techniques including Gold fingers, Blind/Buried hole, Via in pad, etc.
- From FR4 PCBs to Aluminum PCBs, Flex PCBs, Flex-rigid PCBs, Rogers PCBs, etc.
- Free DFM Checking and other custom Electrical Tests (flying probe test, etc.)



[www.pcbcarts.com](http://www.pcbcarts.com)  
[sales@pcbcarts.com](mailto:sales@pcbcarts.com)

## New Products

### i.MX6 SoC Modules Consume Less than 5 W

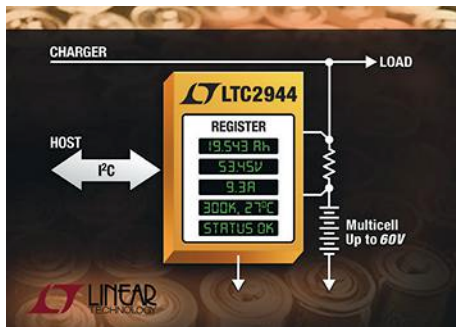
**WITH THEIR FOUR** new FS700 Qseven modules, DFI Tech is now offering one, two, and four Cortex-A9 core i.MX6 NXP (formerly Freescale) versions of Qseven computers on modules. The modules, built with 1.0-GHz SoC processors consuming less than 5 W of power at 5 V, also feature built-in video, 2D graphics, and 3D graphics processors with support for HDMI graphics with resolution up to 1,920 x 1,200 at 60 Hz and dual LVDS interfaces with up to 2,560 x 1,600 at 60-Hz resolution for one port. The modules provide I/O interfaces for CANbus, RS-232, LAN, I<sup>2</sup>S, dual I<sup>2</sup>C, and 4x USB 3.0. They also include a microSD socket, x1 PCIe, and support for expansion to 16 GB of eMMC flash memory.

- The FS700-M60-6S1041 features the single-core i.MX6S processor operating from 0 to 60°C, 1 GB of DDR3, and 4 GB of eMMC.
- The FS700-M60-6L2041 comes with a dual-core i.MX6L processor operating from 0 to 60°C, 2 GB of DDR3, and 4 GB of eMMC.
- The FS700-M60-6D2041 with dual-core i.MX6D processor operating from -40 to 85°C, comes with 2 GB of DDR3 memory, 4 GB of eMMC, and a SATA 2.0 interface.
- The FS700-M60-6Q2081 has a quad-core i.MX6Q processor operating from -40 to 85°C, 2 GB of DDR3 memory, 8 GB of eMMC, and SATA 2.0 interface.



#### DFI TECH

[www.dfitech.com](http://www.dfitech.com)



### 60-V I<sup>2</sup>C Battery Monitor Measures to 1% Accuracy

**THE LTC2944**, a new multicell battery monitor from Linear Technology, makes direct measurements of 3.6- to 60-V battery stacks. No level-shifting circuitry on the supply and measurement pins is required to interface with multicell voltages, so total current consumption is minimized and measurement accuracy is preserved. The true high-voltage battery monitor measures charge, voltage, current, and temperature to 1% accuracy for accurate assessment of battery state of charge.

The monitor is suited for multicell applications, including EVs, ebikes, motorcycles, scooters, wheelchairs, golf carts, and battery-backup systems.

Charge, voltage, current, and temperature information are communicated to the host system over an I<sup>2</sup>C/SMBus-compatible 2-wire interface that's also used to configure the battery monitor. The host can program high and low thresholds for all measured parameters, which if tripped, signal an alert using either the SMBus alert protocol or by setting a register flag.

Offered in commercial (0 to 70°C) and industrial (-40 to 85°C) versions, the LTC2944 multicell battery monitor is available now in an 8-pin, 3- x 3-mm DFN package. Pricing starts at \$2.85 each/1,000.

#### LINEAR TECHNOLOGY

[www.linear.com](http://www.linear.com)

### Current-Sensing High-Voltage Contactor Includes Trip Function

**THE HIGH-VOLTAGE** contactor from TE Connectivity, featuring an integrated current sensor with current trip function, eliminates the need for discrete current sensors in EV, power distribution and energy storage systems. Their small size and flexible configuration are particularly suited for rugged applications. The sensor function includes a programmable trip, which allows immediate, delayed, or disabled trip. The contactors are hermetically sealed for reliable performance in most harsh, explosive, and corrosive environments.

The current-sensing contactors feature a 600-A current rating, 28-600 V dc, and a 1 Form X, SPST-NO DM contact arrangement. KILOVAC KCS03 current-sensing contactors can be mounted in any orientation and include bidirectional switching capabilities to accommodate a range of applications. The integrated dual-coil electronic economizer with coil suppression is EMC-compliant with no radiated coil emissions.

#### TE CONNECTIVITY

[www.te.com](http://www.te.com)



## Rugged Composite Connectors Lose Weight

**TE CONNECTIVITY'S NEXT-GENERATION** ACT composite connectors, DEUTSCH ACT MIL-DTL-38999 Series III, provide high-density contact arrangements in a miniature composite circular connector. Offering 1,500 mating cycles, the composite shells are up to 40% lighter than aluminum connectors. Originally designed as military and aerospace components, ACT series connectors are now being used in many applications requiring extremely reliable interconnections.

Quick mating, environmentally sealed, triple-lead threaded with a self-locking coupling and EMI/RFI shielded, the connectors are resistant to corrosion, having been demonstrated to withstand over 2,000 hours of salt spray. With a scoop-proof design and threaded coupling, mating is secure and vibration resistance is increased.

DEUTSCH ACT MIL-DTL-38999 Series III composite connectors are available in three shell styles, six shell clockings, two platings, and more than 50 different insert arrangements supporting size 22, 20, 16, and 12 contacts for power and signal systems, as well as coax and twinax contacts.

### TE CONNECTIVITY

[www.te.com](http://www.te.com)

## Trimmer Pots Come in J-Hook and Gull-Wing Configurations

**NOW AVAILABLE** from Bourns are the Model PVG3A and PVG3G series of Murata trimmer potentiometers. Available in both J-Hook and Gull-Wing pin styles, the added trimmer products are sized at 3 mm, RoHS-compliant, feature an extended operating temperature range (-55 to 125°C), and have a power rating of 0.25 W at 70°C with a rotational life specified at 50 cycles. Suited for harsh environments, the metal-covered trimmers are sealed and designed to have high heat-resistance performance for high-temperature peak reflow soldering, to help protect the product during manufacturing processing. The cermet trimmers are targeted for small sensors, printers/copiers, optical transceiver modules, and compact power supplies.

The PVG3A and PVG3G single-turn, sealed trimmer series is available now. As a reference, the PVGA501C01R00, 3-mm, single-turn, J hook, cermet Trimmer is priced at \$0.92 each/1,000. Additional Murata trimmer products, models PV12, PVF2, PV32, PV36, PV37, and PVG5, are also available.

### BOURNS

[www.bourns.com](http://www.bourns.com)



## Your Motor Control Experts For All Motor Control Methods



### ZILOG's Line of 32-bit Cortex-M3 based Programmable Motor Controllers

#### Typical Applications:

- BLDC/ PMSM Motors
- Outdoor Air Conditioning
- Washing Machines
- Refrigerators

#### All major development tool environments supported including:

- Keil
- Segger
- IAR
- GCC



#### Key Features:

- High Performance Low-power
- Cortex-M3 Core
- 64KB, 128KB, or 384KB Code Flash
- Memory with Cache function
- 8KB, 12KB, or 24KB SRAM
- Watchdog Timer
- External communication ports
- Six General Purpose Timers

ZNEO32! Evaluation Kits	
Z32F0640100KITG	ZNEO32! 64K Evaluation Kit
Z32F1280100KITG	ZNEO32! 128K Evaluation Kit
Z32F3840100KITG	ZNEO32! 384K Evaluation Kit

Part Number	Core	Flash	SRAM	Max. Freq.	ADC Resolution	ADC Speed	Timers	UART	SPI	I2C	MPWM	ADC	Pkg.
Z32F06410AES	Cortex-M3	64KB	8KB	48MHz	12-bit x 2-unit	1.5MS/s	6-16bit	2	1	1	1	2-unit 11ch	48LQFP
Z32F06410AKS	Cortex-M3	64KB	8KB	48MHz	12-bit x 2-unit	1.5MS/s	6-16bit	2	1	1	1	2-unit 8 ch	32LQFP
Z32F12811ARS	Cortex-M3	128KB	12KB	72MHz	12-bit x 3-unit	1.5MS/s	6-16bit	2	2	2	2	3-unit 16 ch	64LQFP
Z32F12811ATS	Cortex-M3	128KB	12KB	72MHz	12-bit x 3-unit	1.5MS/s	6-16bit	4	2	2	2	3-unit 16 ch	80LQFP
Z32F38412ALS	Cortex-M3	384KB	16KB	72MHz	12-bit x 2-unit	1.5MS/s	10-16bit +FRT	4	2	2	2	2-unit 16 ch	100LQFP
Z32F38412ATS	Cortex-M3	384KB	16KB	72MHz	12-bit x 2-unit	1.5MS/s	10-16bit +FRT	4	2	2	2	2-unit 16 ch	80LQFP



Design With Freedom

For more information, please visit [www.zilog.com](http://www.zilog.com)

## Multi-Channel LXI Digitizers Deliver High-Res Measurements

**EXPANDING THEIR** digitizerNETBOX family, Spectrum is now offering the DN6.44x series, a range of 12 high-speed, 14- and 16-bit LXI-based digitizer products for applications where multiple electronic signals need to be acquired and analyzed. The series allows recording of up to 24 fully synchronized channels with sampling rates of 130 or 250 Msamples/s at 16-bit resolution, or 500 Msamples/s at 14-bit resolution.

The ADCs on each channel are clocked synchronously, and each channel is equipped with its own front-end amplifier with six input ranges ( $\pm 200$  mV,  $\pm 10$  V full scale), switchable input impedance ( $50 \Omega$  and  $1 M\Omega$ ), and programmable positive input offset for unipolar signals. Each instrument also comes equipped with on-board acquisition memory of 512 Msamples per channel and advanced trigger circuitry.

The digitizers are suited for wide-band signal capture in applications where arrays of electronic devices are to be used and tested. Based on the LXI instrumentation standard, the products are also designed for automated testing and remote applications. The fully self-contained instruments feature industrial chassis, replaceable dust filter, and low-noise power supplies, and come with all of the tools necessary to capture, digitize, and analyze waveforms. The DN6.44x series digitizerNETBOX products are available now for immediate delivery.

### SPECTRUM INSTRUMENTATION

[www.spectrum-instrumentation.com](http://www.spectrum-instrumentation.com)



## GoLogic XL Logic Analyzer

### FAST PROBLEM SOLVER



#### Powerful & Versatile

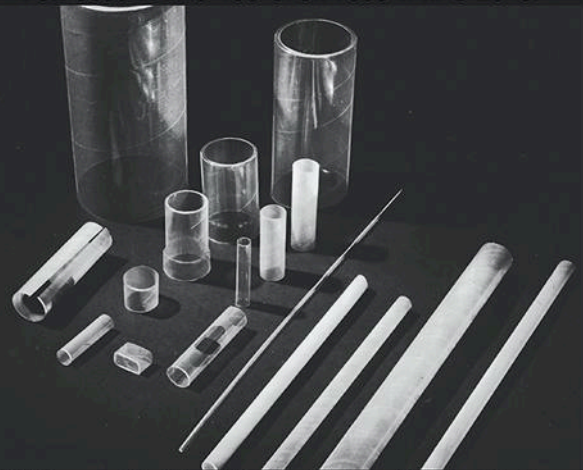
PC Hosted  
Logic Analyzer

- 4GHz sampling
- 1 Billion samples
- 36 or 72 Channels
- ScopeLink Mixed Signal Analysis
- 1 GHz Transitional Sampling
- 300MHz State Analysis



[www.nci-usa.com](http://www.nci-usa.com)  
Phone 256-837-6667  
Fax 256-837-5221  
email: [contact@nci-usa.com](mailto:contact@nci-usa.com)

### SPECIFY "MYLAR"™ INSULATING TUBING FOR COIL WINDING OR COVERS WHEN THE JOB CALLS FOR 5000 VPM @ 150° C. OR 7000 VPM @ 25° C.



"Mylar" has one of the highest dielectric strengths available in a tube form. Its temperature range is from  $-60^{\circ}\text{C}$  to  $+150^{\circ}\text{C}$ . It is moisture-vapor resistant and is unaffected by, and does not transmit, oils, greases and volatile aromatics. It is an exceptionally strong, durable, transparent film with high tensile, tear and impact strength. Also in heat-shrinkable grade

To receive literature & details fast - [www.pptube.com](http://www.pptube.com)

Phone: 847-537-4250 • Fax: 847-537-5777 • E-Mail: [sales@pptube.com](mailto:sales@pptube.com)

™ © DuPont Co.



More Than 80 Years - The Original

## Precision

Paper Tube Company

1033 S. Noel Ave., Wheeling, IL 60090



## Compact DC-DC Converter Offers 10:1 Input Voltage

**BEL POWER SOLUTIONS'** new MELCHER HP Series dc-dc converter (4TE), with an input voltage range greater than 10:1, offers up to 192 W with typical efficiency up to 93% over input and load range with no derating over the operating ambient temperature range of -40 to 70°C. Just one power supply covers all nominal battery voltages from 24 V to 110 V, particularly suiting it for railway applications. The continuous input voltage range is 16.8 to 137.5 V, with dynamic transient deviations to 12.5 V and 154 V for two seconds, respectively. Output covers 5 to 96 V in single-, dual-, triple-, or quad-output configurations, and standard features include current share, 10-ms interruption time, reverse-polarity protection, in-rush current limitation, overvoltage and user-programmable undervoltage lockout, remote on/off, and adjustable output voltage. The MELCHER HP Series is packaged in a rugged cassette case with a variety of electrical and mechanical accessories available, including a universal mounting bracket for DIN rail and chassis mounting, a mounting plate for wall mounting, and a front-panel kit for accommodating 2 HP units for a 19-in. DIN rack with 6U, 5TE.

**MOUSER**

[www.mouser.com](http://www.mouser.com)

## Square Body GDTs Protect Against O/V Transients

**THE SH SERIES** squared gas-discharge tube was designed by Littelfuse to provide high levels of protection against fast-rising transients caused by lightning disturbances. Measuring 5.0 × 5.0 × 4.2 mm, the series provides 5-kA surge capability and a ≤0.7-pF off-state capacitance value that minimizes insertion loss and does not vary as the signal voltage varies; thus, it does not demodulate the signal of interest. These features provide protection of electrical, multimedia, and communication equipment against overvoltage transients in high-speed, wide-bandwidth applications such as G.fast, xDSL, 10 GbE, and 10/100/1000Base-T Ethernet port protection; coaxial cable protection in satellite; CATV equipment; industrial automation interfaces (e.g., Ethernet, RS-485 and RS-232); and ac power-line protection in power inverters and VFDs for the renewable energy market.

**LITTELFUSE**

[www.littelfuse.com](http://www.littelfuse.com)



**pcim**  
EUROPE

International Exhibition and Conference  
for Power Electronics, Intelligent Motion,  
Renewable Energy and Energy Management  
Nuremberg, 16 – 18 May 2017


power semiconductors inductors magnetic materials  
passive components core materials Industry electronics

... share the moment!

electrical drives power converters engine control sensors  
thermal management measurement power supply test  
power quality energy storage automotive electronics

Get your free ticket at  
[pcim-europe.com/moment](http://pcim-europe.com/moment)  
Your registration code  
1712323293PEMI

More information at:  
+49 711 61946-820  
[pcim@mesago.com](mailto:pcim@mesago.com)

Follow us  
 #pcimeurope

**mesago**  
Messe Frankfurt Group



QM35



QML35

## Today's Solution for Tomorrow's Automation

- Encoders to fit your Requirements
  - Quick, Dependable Delivery
  - Proven Reliability and Quality

**Quantum**  
**Devices**

**Contact Us Today!**  
[www.quantumdev.com](http://www.quantumdev.com)  
(608) 924-3000

**600-V Power MOSFET Increases Efficiency**

**THE SIHP065N60E**, the first device in Vishay's fourth generation of 600-V E Series power MOSFETs, provides high efficiency for telecom, industrial, and enterprise power-supply applications. The Siliconix n-channel device slashes on-resistance by 30 % compared with previous 600-V E Series MOSFETs while delivering 44 % lower gate charge.

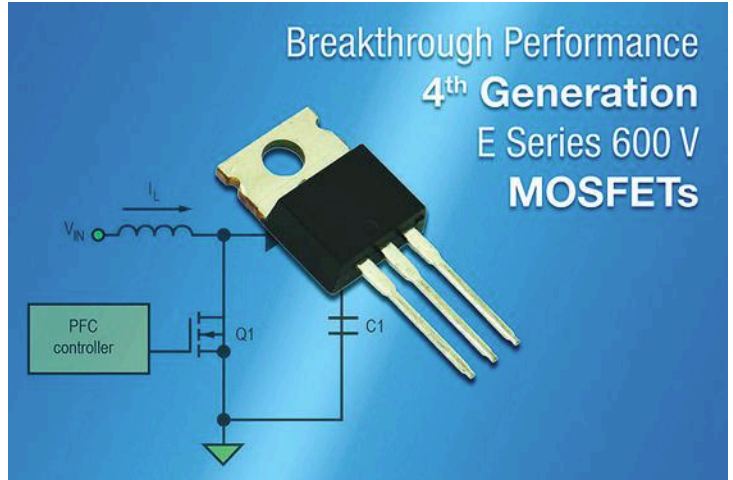
Built on Vishay's latest energy-efficient E Series superjunction technology, the MOSFET features low maximum on-resistance of 0.065  $\Omega$  at 10 V, and ultra-low gate charge down to 49 nC. For improved switching performance, the device provides low effective output capacitances  $C_{o(er)}$  and  $C_{o(tr)}$  of 93 and 593 pF, respectively.

These values translate into reduced conduction and switching losses to save energy in power-factor-correction and hard-switched dc-dc converter topologies.

Offered in a TO-220AB package, the device is RoHS-compliant, halogen-free, and designed to withstand overvoltage transients in avalanche mode with guaranteed limits through 100% UIS testing. Samples and production quantities of the SIHP065N60E 600-V E Series power MOSFET are available now, with lead times of 10 weeks. Pricing starts at \$4.79 each/1,000.

**VISHAY**

[www.vishay.com](http://www.vishay.com)





**REFUSE TO LET DESIGN FALL FLAT**

Request free design cube at [go.protolabs.com/ED7SA](http://go.protolabs.com/ED7SA).

**proto labs**® 3D PRINTING  
CNC MACHINING  
INJECTION MOLDING  
Real Parts. Really Fast.

**ED 4/16 ISSUE PREVIEW**  
Ad Close: 3/7/17  
Materials Due: 3/14/17

**TECHNOLOGY:**  
Embedded

**INDUSTRY TRENDS**  
Voltage Regulator ICs

**PRODUCT TRENDS**  
Wireless Tests

**ENGINEERING ESSENTIALS**  
MEDICAL IOT

<http://electronicdesign.com>

**Texas Instruments** is looking to fill engineering positions working with semiconductor technologies. We are recruiting @ various educational and experience levels:

CITY	POSITION	APPLY FOR JOB USING THIS LINK
Dallas/Richardson, TX	Analog Design Engineer	<a href="http://tinyurl.com/kgjueje">http://tinyurl.com/kgjueje</a>
	Applications Engineer	<a href="http://tinyurl.com/m4yea5c">http://tinyurl.com/m4yea5c</a>
	Digital Design Engineer	<a href="http://tinyurl.com/k4vss9c">http://tinyurl.com/k4vss9c</a>
	Packaging Engineer	<a href="http://tinyurl.com/l3bfq4k">http://tinyurl.com/l3bfq4k</a>
	Process Development Engineer	<a href="http://tinyurl.com/lpce2oz">http://tinyurl.com/lpce2oz</a>
	Product Marketing Engineer	<a href="http://tinyurl.com/kmjeqdz">http://tinyurl.com/kmjeqdz</a>
	Product Marketing Manager	<a href="http://tinyurl.com/hxdjw8z">http://tinyurl.com/hxdjw8z</a>
	Production Planning Analyst	<a href="http://tinyurl.com/jw426ar">http://tinyurl.com/jw426ar</a>
	Program Management Engineer	<a href="http://tinyurl.com/zeo2kr2">http://tinyurl.com/zeo2kr2</a>
	Software Engineer	<a href="http://tinyurl.com/gp8takh">http://tinyurl.com/gp8takh</a>
	Systems Applications Engineer	<a href="http://tinyurl.com/j6lqpqs">http://tinyurl.com/j6lqpqs</a>
	Systems Engineer	<a href="http://tinyurl.com/phqrsr">http://tinyurl.com/phqrsr</a>
	Validation/Character Engineer	<a href="http://tinyurl.com/nlyrcqw">http://tinyurl.com/nlyrcqw</a>
Cary, NC	Analog Design Engineer	<a href="http://tinyurl.com/z7xnecy">http://tinyurl.com/z7xnecy</a>
Santa Clara/Sunnyvale, CA	Analog Design Engineer	<a href="http://tinyurl.com/ke86n9o">http://tinyurl.com/ke86n9o</a>
	Applications Engineer	<a href="http://tinyurl.com/z43za6g">http://tinyurl.com/z43za6g</a>
	Applications Manager	<a href="http://tinyurl.com/l3wlmn">http://tinyurl.com/l3wlmn</a>
	Digital Design Engineer	<a href="http://tinyurl.com/z9qd2h8">http://tinyurl.com/z9qd2h8</a>
	Design Support Engineer	<a href="http://tinyurl.com/jtoe4aj">http://tinyurl.com/jtoe4aj</a>
San Diego, CA	Packaging Engineer	<a href="http://tinyurl.com/pjqw6hh">http://tinyurl.com/pjqw6hh</a>
	Test Engineer	<a href="http://tinyurl.com/lgtcyur">http://tinyurl.com/lgtcyur</a>
San Diego, CA	Applications Manager	<a href="http://tinyurl.com/l3wlmn">http://tinyurl.com/l3wlmn</a>
Sugar Land, TX	Software Engineer	<a href="http://tinyurl.com/q7xzjag">http://tinyurl.com/q7xzjag</a>
	Systems Applications Engineer	<a href="http://tinyurl.com/jr5wka6">http://tinyurl.com/jr5wka6</a>
Tucson, AZ	Analog Design Engineer	<a href="http://tinyurl.com/m6hgk9e">http://tinyurl.com/m6hgk9e</a>
	Digital Design Engineer	<a href="http://tinyurl.com/m2987g8">http://tinyurl.com/m2987g8</a>
	Marketing Manager	<a href="http://tinyurl.com/goa2tv7">http://tinyurl.com/goa2tv7</a>
	Systems Engineer	<a href="http://tinyurl.com/lpaz7vo">http://tinyurl.com/lpaz7vo</a>
	Test Engineer	<a href="http://tinyurl.com/lrv6n5n">http://tinyurl.com/lrv6n5n</a>

Some positions may require travel.  
Please send in resumes using the individual URL code for the position listed. EOE.

Ad	Page
Avtech Electrosystems Ltd.....	7
Beta-Layout USA.....	54
Coilcraft.....	1
Dean Technology.....	17
Digi-Key.....	FC, IFC
IXYS.....	30
Kensington Electronics.....	21
Keystone Electronics.....	5
Linear Integrated Systems.....	6
Linear Technology Corp. 48A/B, BC	
LPKF Laser & Electronics.....	18
Memory Protective Devices.....	37
Mesago Messe Frankfurt GMBH	53
NCL.....	52
PCBcart (General Circuits, Ltd.).	49
Pico Electronics Inc.....	47
Positronic Industries.....	28

Ad	Page
Precision Paper Tube Company ...	52
Proto Labs, Inc.....	IBC
Quantum Devices Inc. ....	53
Radicom Research.....	46
Stanford Research Systems.....	39
Tadiran Lithium Batteries.....	33
Tag Connect.....	54
TE Connectivity.....	25
The Bergquist Company.....	8
Zilog.....	51
Zurich Instruments.....	2

**For more information on products or services visit our website [www.electronicdesign.com](http://www.electronicdesign.com). The advertisers index is prepared as an extra service. *Electronic Design* does not assume any liability for omissions or errors.**

**27 GHz Bandwidth Open Top Socket for BGA121**

Ironwood Electronics has recently introduced a new high performance BGA socket for 1mm pitch, 121 pin BGA IC's. The SG-BGA-6457 socket is designed for IC size - 12x12mm package size and operates at bandwidths up to 27 GHz with less than 1dB of insertion loss.



The contact resistance is typically 20 milliohms per pin. The socket connects all pins with 27 GHz bandwidth on all connections.

**Ironwood Electronics, Inc.**  
1335 Eagandale Court  
Eagan, MN 55121  
T: 800-404-0204 • F: 952-229-8201  
Email: [info@ironwoodelectronics.com](mailto:info@ironwoodelectronics.com)  
Web Site: [www.ironwoodelectronics.com](http://www.ironwoodelectronics.com)



# Do Circuit Boards Need More Wires?

Printed circuit boards support high-speed serial connections—for now. Faster SerDes is forcing designers to look at cabling alternatives.

remember when single-sided printed circuit boards (PCBs) with wires dominated many markets—like whitegoods—because it was possible to keep costs down. This is still done in some instances, but these days, multilayer PCBs are the norm. While these handle the fastest high-speed serial interfaces, the move to 56 Gbit/s SerDes (Serializer/Deserializer) may give PCB designers a run for their money, owing to the difficulty of handling the high-speed signals on large PCBs. Issues also arise when moving from board to board, including connector design challenges.

One alternative is to bypass the PCB and use wires to connect point A to point B. This is sometimes done for convenience or to simplify PCB design, but in the future it may be required to handle high-speed applications. One mid-board wiring solution is TE Connectivity's Sliver system (Fig. 1). The current incarnation supports 12 and 25 Gbit/s communication links that are sufficient for today's high-speed serial standards like PCI Express, Ethernet, and InfiniBand.

The company was showing off a version that is designed for 56 Gbit/s SERDES support at DesignCon 2017. This faster SerDes is only being used in research and evaluation at this point, but it is likely that ultraminiature coax might be the way to connect high-speed signals across a board or between boards.


Sliver, with high density 0.6-mm contact pitch, is already used for existing high-speed serial connections. The connection is much more efficient than a pair of PCB traces, and routing is often easier. This can also allow the designer to use less-expensive materials or fewer layers, since the high-speed connections bypass the PCB. Of course, this isn't something that would be done with all signals, but it is usually sufficient to route one or two bus connections in many systems.

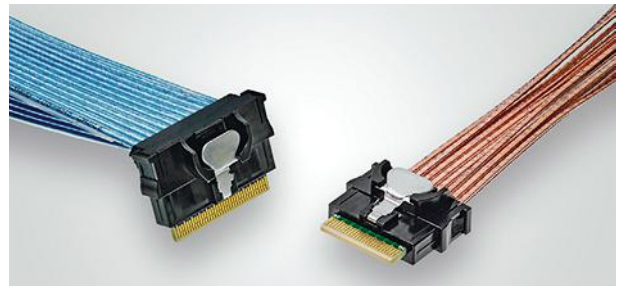
Sometime optical connections may be more appropriate. Samtec's FireFly system (see "Backplane Optical Interconnects Speed Past Copper" on [electronicdesign.com](http://electronicdesign.com)) combines optical transceivers with the connectors at each end (Fig. 2). The connectors also incorporate a heatsink to cool the transceivers.

The optical approach is more expensive because of much more complicated active connectors at each end. On the other

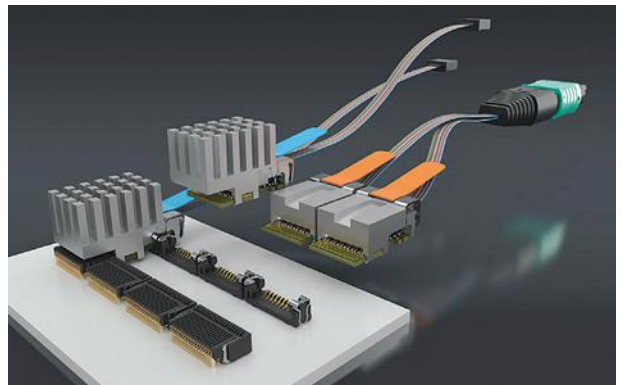
hand, there are advantages to using fiber connections from reduced crosstalk and more robust EMI support to the ability to utilize longer fiber connections than is possible with copper solutions.

The Consortium for On-board Optics (COBO) is working on standardizing the optical mid-board approach that is currently dominated by vendor-specific implementations.

These connector and cabling systems provide designers with alternatives to conventional PCB designs. Optical may eventually be the wave of the future, but copper is definitely solving high-speed connection problems today. 



1. TE Connectivity's current Sliver implementations handle signal speeds up to 25 G.



2. Samtec's FireFly system can support up to a dozen optical transceivers and handle speeds up to 28 Gbits/s.

# INJECTION MOLDING THAT CRUSHES CONVENTIONAL MANUFACTURING WISDOM.

At Proto Labs, we have the automation and capacity to deliver low-volume production runs in just 15 days or less. We call this a game-changer.

## DIGITAL MANUFACTURING FOR THOSE WHO NEED PARTS **TOMORROW.**

**proto labs**<sup>®</sup>  
Real Parts. Really Fast.<sup>®</sup>

3D PRINTING | CNC MACHINING | INJECTION MOLDING

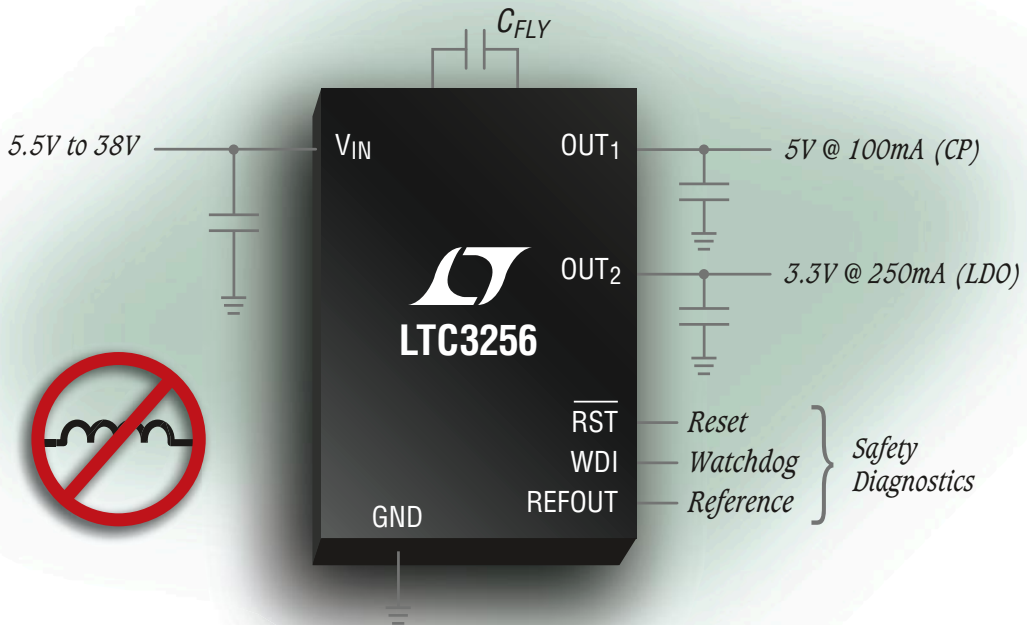
ISO 9001: 2008 Certified | ITAR Registered | © 2017 Proto Labs, Inc.



### FREE BOOK

Request your Injection Molding for Dummies book at [go.protolabs.com/ED7ED](https://go.protolabs.com/ED7ED).

# Save Space & Reduce EMI

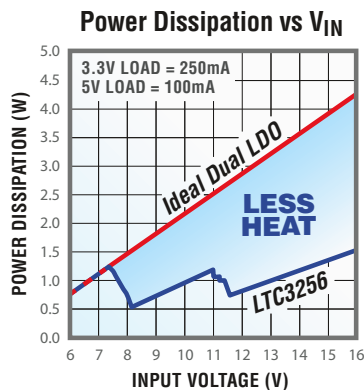


## 38V<sub>IN</sub>, Dual Outputs, Low Power Loss Charge Pump & LDO

The LTC3256 is a wide input voltage range, dual output charge pump and LDO combination, capable of delivering a fixed 5V output at 100mA and a fixed 3.3V at 250mA. This combination enables up to 2.8W less power loss compared to two LDOs, useful in thermally constrained applications. Furthermore, its inductorless topology and low EMI emissions are ideal for compact industrial and automotive applications. In addition to its 38V maximum input and 20µA quiescent current, the watchdog timer and power-on reset allow easy interface to a microcontroller.

### ▼ Features

- 5.5V to 38V Input Voltage Range
- Independently Enabled 5V & 3.3V Fixed Outputs
- 5V Charge Pump Output: 100mA Max.
- 3.3V LDO Output: 250mA Max.
- 20uA Quiescent Current (Both Outputs on)
- Engineered for Diagnostic Coverage in ISO26262 Systems



### ▼ Info & Free Samples

[www.linear.com/product/LTC3256](http://www.linear.com/product/LTC3256)  
1-800-4-LINEAR



**Download**  
"High Voltage Charge Pump IC Solutions"  
[www.linear.com/HVchargepump](http://www.linear.com/HVchargepump)

LT, LT, LTC, LTM, Linear Technology, and the Linear logo are registered trademarks of Linear Technology Corporation. All other trademarks are the property of their respective owners.